



PRODUCTIVITY GUIDE MAGNUM™ & STEIGER® TRACTORS



PRODUCTIVITY DELIVERED DAILY

CASE IH DELIVERS QUALITY PARTS AND SERVICE EVERY TIME.

At Case IH, we have what it takes to maximize your equipment's power and productivity all season long. Our extensive dealer network means we're always close by. Our resourceful parts and service support team understands your unique needs to help you operate more efficiently. And our wide range of precision engineered Case IH parts matches your operation's systems for greater productivity and uptime. It's all the genuine parts and expert support you expect—under one sign. Visit us today.

QUALITY SERVICE

- **FACTORY TRAINED TECHNICIANS**
- **GENUINE CASE IH PARTS**
- **DOCUMENTED MAINTENANCE**
- **INCREASE PRODUCTIVITY**
- **LESS DOWNTIME**

Flexible revolving account financing with the CNH Capital Revolving Account is designed to match your unique cash flow requirements and payment schedules.

CASE IH ORIGINAL PARTS

- **DESIGNED TO MEET STRINGENT CASE IH QUALITY, RELIABILITY AND PERFORMANCE**
- **GUARANTEED BY CASE IH**
- **DESIGNED SPECIFICALLY FOR CASE IH EQUIPMENT**
- **MADE BY MANUFACTURERS WITH WORLDWIDE REPUTATIONS**



MAKE FARM SAFETY A PRIORITY

The second most important part of your farming operation is getting the job done right. Farm safety is the most important aspect in all farming operations. None of the things you accomplish on your farm are worth much if you don't end each day safe and sound.

The National Safety Council or the American Farm Bureau confirms that farming is the most hazardous occupation in the nation today. They will also tell you that most farm accidents are caused because of failure to follow well publicized safety precautions.

Case IH engineers incorporate safety into every machine they design. After your tractor is delivered, read the Operator's Manual and carefully note all of the safety instructions contained in it. Be alert to all safety suggestions. Farm safety is ultimately your own responsibility. You owe it to your family to work safely. The most important safety device on a tractor is the Roll Over Protection Structure (ROPS) with an effective seat belt. More farmers are killed or seriously injured from tractor roll overs than from any other type of farm accident. Read all of the safety instructions in your Operator's Manual and be sure you can give a positive response to all of the following:

- **Shields** - Is the PTO master shield in place? Are all other shields in place?
- **Warning Decals** - Are all warning decals in place and readable? Is the slow moving vehicle (SMV) emblem in place and in good condition?
- **Fuel System** - Is the fuel cap in good condition without fuel leaks?
- **Lights** - Are the emergency flashing lights (for road travel), turn signals, head lights, and tail lights in working order?
- **Brakes** - Do the brakes apply evenly when applied together?
- **Starting** - Start the engine only when properly seated in the operator's seat. When starting in cold weather, the tractor could move as the transmission is engaged even with the clutch pedal depressed. Use the brakes to prevent tractor movement.
- **Other People** - Be sure all others are clear of the tractor and equipment. No riders.
- **Road Travel** - For safe operation on the road, always lock the brake pedals together with the pedal interlock. Do not exceed 20 mph (32 kph) while transporting implements.
- **Tractor Stability** - Always reduce travel speed on turns or rough ground, and avoid steep slopes. Pull only from the drawbar...never higher.
- **Fumes** - Be careful about carbon monoxide fumes. Remember that agricultural herbicides and other pesticides can be hazardous. Your tractor cab air filter cannot remove fumes, exhaust or chemical. Follow instructions and precautions from the manufacturers of the equipment and the chemicals regarding inhalation of dust, fumes or spray.
- **Implement Operation** - Be sure implement reflectors are undamaged and unfaded. Make sure all guards are in place over auger intake areas. Test remote shutoff devices to assure they are working properly.



WHEN YOU NEED HELP, YOUR DEALER IS THERE

Everything you need to keep your tractor operating profitably, efficiently, and safely is right at your Case IH dealership.

Do you need service work on a tractor, emergency field service, or parts in a hurry? Your dealer is ready and able to help.

Case IH factory-trained service technicians are experts on the inner workings of your Case IH tractors. The parts department is well stocked with all the parts, belts, filters, lubricants, and engine parts you'll need. Don't take a chance on second best.

THINK SAFE. WORK SAFE. BE SAFE.

PRODUCTIVITY GUIDE

TAKE FULL ADVANTAGE OF ITS CAPABILITIES.

GETTING THE MOST FROM YOUR CASE IH TRACTOR IS THE PURPOSE OF THIS BOOKLET. CASE IH WANTS TO HELP OWNERS GET MORE EFFICIENCY FROM ALL OF THEIR EQUIPMENT.



Did you, or someone you know, purchase a new tractor in the last few years and continue to use it in much the same way you as tractor it replaced? Many times operators do not fully realize and take advantage of modern features like electronic engine performance and performance monitors. As a result of not fully utilizing the tractor's features, the owner may not be getting all the value from the money spent.

Many of the items suggested in this booklet can be completed by the owner when preparing for the season or the operator when starting a new field. Other adjustments, service procedures, or repairs might be more effectively completed by your dealer's trained service technicians.

MAINTENANCE CHOICES, BEING PREPARED FOR DEMANDING CONDITIONS

Ask your Case IH dealer about Customized Maintenance Inspections. It is a proactive way to be sure your tractor will operate at its best possible performance when you need it.

Customized Maintenance Inspections include a visual and functional inspection of your tractor. They can be used as a pre-season or as a post-season tune-up. Benefits include:

- INCREASED PRODUCTIVITY
- LESS DOWNTIME DURING THE SEASON
- LOWER OPERATING COSTS
- IMPROVED FUEL ECONOMY
- DOCUMENTED MAINTENANCE
- SERVICED BY CASE IH TRAINED TECHNICIANS
- SERVICED WITH GENUINE CASE IH LUBRICANTS, FILTERS, & PARTS

The combined advantages of CMI services should result in a lower cost of ownership and higher resale values.

DOCUMENTED SERVICE PROMOTES HIGH RESALE VALUE

When you schedule your equipment for annual maintenance inspection services, your Case IH dealership places annual UPTIME Action Maintenance decals on your equipment after each inspection, distinguishing your commitment to keep your machines running in top condition. Not only does annual maintenance support your productivity in the field, each decal symbolizes completed service—which may increase the resale value of your equipment.

Because Case IH technicians use Customized Maintenance Inspection Checklists for each inspection, you can rest assured that the service is thorough and nothing is overlooked.



SERVICE INSPECTIONS

STEIGER SERIES TRACTORS

ASK YOUR DEALER ABOUT PERFORMING A CUSTOMIZED MAINTENANCE INSPECTION SERVICE TO KEEP YOU UP AND RUNNING!

SAFETY EQUIPMENT		INSPECT/SERVICE		STEERING SYSTEM		INSPECT/SERVICE		HITCH/PTO AREA		INSPECT/SERVICE	
1.	Seat Belts	<input type="checkbox"/>	<input type="checkbox"/>	43.	Hoses	<input type="checkbox"/>	<input type="checkbox"/>	75.	Inspect Hitch Members	<input type="checkbox"/>	<input type="checkbox"/>
2.	ROPs	<input type="checkbox"/>	<input type="checkbox"/>	44.	Cylinders/Valves	<input type="checkbox"/>	<input type="checkbox"/>	76.	Upper Link Operational	<input type="checkbox"/>	<input type="checkbox"/>
3.	Warning/Flashing Lights	<input type="checkbox"/>	<input type="checkbox"/>	45.	Steering Stops, Adjust	<input type="checkbox"/>	<input type="checkbox"/>	77.	Proper Height	<input type="checkbox"/>	<input type="checkbox"/>
4.	Decals in place (SMV)	<input type="checkbox"/>	<input type="checkbox"/>	46.	Operational	<input type="checkbox"/>	<input type="checkbox"/>	78.	Engage/Disengage	<input type="checkbox"/>	<input type="checkbox"/>
5.	Other Audible Sounds	<input type="checkbox"/>	<input type="checkbox"/>	47.	Tilt & Telescope	<input type="checkbox"/>	<input type="checkbox"/>	79.	Remote Switches	<input type="checkbox"/>	<input type="checkbox"/>
6.	Horn	<input type="checkbox"/>	<input type="checkbox"/>	POWER TRAIN				QUADTRACK & UNDERCARRIAGE			
7.	PTO Shield in place	<input type="checkbox"/>	<input type="checkbox"/>	48.	Transmission Oil Level	<input type="checkbox"/>	<input type="checkbox"/>	80.	Track Alignment	<input type="checkbox"/>	<input type="checkbox"/>
8.	Reflectors	<input type="checkbox"/>	<input type="checkbox"/>	49.	Axle Oil Level	<input type="checkbox"/>	<input type="checkbox"/>	81.	Roller wheel oil level	<input type="checkbox"/>	<input type="checkbox"/>
9.	Mirrors	<input type="checkbox"/>	<input type="checkbox"/>	50.	Check For All Gears	<input type="checkbox"/>	<input type="checkbox"/>	82.	Track TM Numbers		
ENGINE				51.	Inching Pedal	<input type="checkbox"/>	<input type="checkbox"/>		LF _____ RF _____		
10.	Oil Level	<input type="checkbox"/>	<input type="checkbox"/>	52.	Wheel Lugs	<input type="checkbox"/>	<input type="checkbox"/>		LR _____ RR _____		
11.	Engine Oil Filter	<input type="checkbox"/>	<input type="checkbox"/>	53.	Tires/Pressure	<input type="checkbox"/>	<input type="checkbox"/>	ADDITIONAL MAINTENANCE			
12.	Exhaust Smoke	<input type="checkbox"/>	<input type="checkbox"/>	BRAKE SYSTEM				83.	Window/Door Latch Adjustment	<input type="checkbox"/>	<input type="checkbox"/>
13.	Unusual Noise	<input type="checkbox"/>	<input type="checkbox"/>	54.	Lines/Hoses	<input type="checkbox"/>	<input type="checkbox"/>	84.	Hood Tilt-Retention/Sealing	<input type="checkbox"/>	<input type="checkbox"/>
14.	High & Low Idle Speeds	<input type="checkbox"/>	<input type="checkbox"/>	55.	Foot Brake	<input type="checkbox"/>	<input type="checkbox"/>	85.	Lube Grease Points	<input type="checkbox"/>	<input type="checkbox"/>
15.	Turbo Charger	<input type="checkbox"/>	<input type="checkbox"/>	56.	Parking Brake	<input type="checkbox"/>	<input type="checkbox"/>	86.	Engine Air Filters	<input type="checkbox"/>	<input type="checkbox"/>
16.	Intake System	<input type="checkbox"/>	<input type="checkbox"/>	COOLING SYSTEM				87.	Engine Fuel Filters	<input type="checkbox"/>	<input type="checkbox"/>
17.	Muffler/Exhaust System	<input type="checkbox"/>	<input type="checkbox"/>	57.	Radiator Core	<input type="checkbox"/>	<input type="checkbox"/>	88.	Engine Valve Lash Adj**	<input type="checkbox"/>	<input type="checkbox"/>
18.	Fuel Pumps	<input type="checkbox"/>	<input type="checkbox"/>	58.	Hoses/Clamps/Radiator Cap	<input type="checkbox"/>	<input type="checkbox"/>	89.	Hyd. Filters	<input type="checkbox"/>	<input type="checkbox"/>
19.	Fuel Line/Clamps	<input type="checkbox"/>	<input type="checkbox"/>	59.	Water Pump	<input type="checkbox"/>	<input type="checkbox"/>	90.	Fuel Injectors	<input type="checkbox"/>	<input type="checkbox"/>
20.	Fuel Shut Off System	<input type="checkbox"/>	<input type="checkbox"/>	60.	Fan Assembly	<input type="checkbox"/>	<input type="checkbox"/>	91.	Coolant/Filters	<input type="checkbox"/>	<input type="checkbox"/>
21.	Fuel Throttle Linkage	<input type="checkbox"/>	<input type="checkbox"/>	61.	Coolant/_____ ° F/C	<input type="checkbox"/>	<input type="checkbox"/>	92.	Cab Filters	<input type="checkbox"/>	<input type="checkbox"/>
22.	Fuel Tank	<input type="checkbox"/>	<input type="checkbox"/>	62.	Coolant Recovery	<input type="checkbox"/>	<input type="checkbox"/>	93.	Clean A/C Condensor	<input type="checkbox"/>	<input type="checkbox"/>
23.	Water/Sediment Drain	<input type="checkbox"/>	<input type="checkbox"/>	HYDRAULIC				94.	A/C Check	<input type="checkbox"/>	<input type="checkbox"/>
24.	Fuel Cap	<input type="checkbox"/>	<input type="checkbox"/>	63.	Oil Level	<input type="checkbox"/>	<input type="checkbox"/>	FLUID ANALYSIS (VALIDATED THRU INTERNET SITE)			
25.	Belts/Tensioner	<input type="checkbox"/>	<input type="checkbox"/>	64.	Lines/Hoses.	<input type="checkbox"/>	<input type="checkbox"/>	95.	Coolant Analysis (cc 2700 kit)	<input type="checkbox"/>	<input type="checkbox"/>
26.	Ether Assist	<input type="checkbox"/>	<input type="checkbox"/>	65.	Control/Linkage	<input type="checkbox"/>	<input type="checkbox"/>	96.	Engine Oil Sample	<input type="checkbox"/>	<input type="checkbox"/>
27.	Block Heater	<input type="checkbox"/>	<input type="checkbox"/>	66.	Oil Cooler	<input type="checkbox"/>	<input type="checkbox"/>	97.	Transmission Oil Sample	<input type="checkbox"/>	<input type="checkbox"/>
ELECTRICAL				67.	Cylinders/Valves	<input type="checkbox"/>	<input type="checkbox"/>	98.	Hydraulic Oil Sample	<input type="checkbox"/>	<input type="checkbox"/>
28.	Neutral Starting Switch	<input type="checkbox"/>	<input type="checkbox"/>	68.	Reservoir	<input type="checkbox"/>	<input type="checkbox"/>	99.	Front Axle Oil Sample*	<input type="checkbox"/>	<input type="checkbox"/>
29.	Connections	<input type="checkbox"/>	<input type="checkbox"/>	69.	Operational	<input type="checkbox"/>	<input type="checkbox"/>	100.	Rear Axle Oil Sample*	<input type="checkbox"/>	<input type="checkbox"/>
30.	Battery Fluid	<input type="checkbox"/>	<input type="checkbox"/>	70.	Proper Detent	<input type="checkbox"/>	<input type="checkbox"/>	*If separate compartment			
31.	Battery Hold Down	<input type="checkbox"/>	<input type="checkbox"/>	71.	Quick Couplers	<input type="checkbox"/>	<input type="checkbox"/>	MISCELLANEOUS			
32.	Battery Voltage	<input type="checkbox"/>	<input type="checkbox"/>	LEAKS				101.	Welds/Frames	<input type="checkbox"/>	<input type="checkbox"/>
33.	Battery Area Clear/Clean	<input type="checkbox"/>	<input type="checkbox"/>	72.	Oil	<input type="checkbox"/>	<input type="checkbox"/>	102.	Exterior Condition	<input type="checkbox"/>	<input type="checkbox"/>
34.	Starter	<input type="checkbox"/>	<input type="checkbox"/>	73.	Coolant	<input type="checkbox"/>	<input type="checkbox"/>	103.	Seat Operates/Condition	<input type="checkbox"/>	<input type="checkbox"/>
35.	Alternator	<input type="checkbox"/>	<input type="checkbox"/>	74.	Fuel	<input type="checkbox"/>	<input type="checkbox"/>	104.	Operator's Manual	<input type="checkbox"/>	<input type="checkbox"/>
36.	Wipers/Washers	<input type="checkbox"/>	<input type="checkbox"/>								
37.	Heat/AC Fan	<input type="checkbox"/>	<input type="checkbox"/>								
38.	Turn Signals	<input type="checkbox"/>	<input type="checkbox"/>								
39.	Lights	<input type="checkbox"/>	<input type="checkbox"/>								
40.	Check/Clear Fault Codes	<input type="checkbox"/>	<input type="checkbox"/>								
41.	Differential Lock	<input type="checkbox"/>	<input type="checkbox"/>								
42.	Instrumentation/Warning Lights	<input type="checkbox"/>	<input type="checkbox"/>								

** Adjust valve lash if Operator's Manual scheduled interval has been reached at time of inspection.

MAGNUM SERIES TRACTORS

ASK YOUR DEALER ABOUT PERFORMING A CUSTOMIZED MAINTENANCE INSPECTION SERVICE TO KEEP YOU UP AND RUNNING!

SAFETY EQUIPMENT		INSPECT/SERVICE		STEERING SYSTEM		INSPECT/SERVICE		HITCH/PTO AREA		INSPECT/SERVICE	
1. Seat Belts	<input type="checkbox"/>	<input type="checkbox"/>	44. Hoses	<input type="checkbox"/>	<input type="checkbox"/>	78. Inspect Hitch Members	<input type="checkbox"/>	<input type="checkbox"/>			
2. ROPs	<input type="checkbox"/>	<input type="checkbox"/>	45. Cylinder/Valves	<input type="checkbox"/>	<input type="checkbox"/>	79. Upper Link Operational	<input type="checkbox"/>	<input type="checkbox"/>			
3. Warning/Flashing Lights	<input type="checkbox"/>	<input type="checkbox"/>	46. Tie Rods/Knuckles	<input type="checkbox"/>	<input type="checkbox"/>	80. Proper Height	<input type="checkbox"/>	<input type="checkbox"/>			
4. Decals in place (SMV)	<input type="checkbox"/>	<input type="checkbox"/>	47. Operational	<input type="checkbox"/>	<input type="checkbox"/>	81. Engage/Disengage	<input type="checkbox"/>	<input type="checkbox"/>			
5. Other Audible Sounds	<input type="checkbox"/>	<input type="checkbox"/>	48. Front Wheel Toe In	<input type="checkbox"/>	<input type="checkbox"/>	ADDITIONAL MAINTENANCE					
6. Horn	<input type="checkbox"/>	<input type="checkbox"/>	49. Tilt & Telescope	<input type="checkbox"/>	<input type="checkbox"/>	82. Lube Grease	<input type="checkbox"/>	<input type="checkbox"/>			
7. Brake Pedal Interlock	<input type="checkbox"/>	<input type="checkbox"/>	POWER TRAIN			83. Engine Air Filters	<input type="checkbox"/>	<input type="checkbox"/>			
8. PTO Shield in place	<input type="checkbox"/>	<input type="checkbox"/>	50. Planetary Oil	<input type="checkbox"/>	<input type="checkbox"/>	84. Engine Fuel Filters	<input type="checkbox"/>	<input type="checkbox"/>			
9. Reflectors	<input type="checkbox"/>	<input type="checkbox"/>	51. Differential Oil	<input type="checkbox"/>	<input type="checkbox"/>	85. Hyd. Filters	<input type="checkbox"/>	<input type="checkbox"/>			
10. Mirrors	<input type="checkbox"/>	<input type="checkbox"/>	52. Check for All Gears	<input type="checkbox"/>	<input type="checkbox"/>	86. Wheel Bearings	<input type="checkbox"/>	<input type="checkbox"/>			
ENGINE			53. Inching Pedal	<input type="checkbox"/>	<input type="checkbox"/>	87. Eng. Valve Lash Adj.*	<input type="checkbox"/>	<input type="checkbox"/>			
11. Engine Oil/Filter	<input type="checkbox"/>	<input type="checkbox"/>	54. Wheel Lugs	<input type="checkbox"/>	<input type="checkbox"/>	88. Fuel Injectors	<input type="checkbox"/>	<input type="checkbox"/>			
12. Exhaust Smoke	<input type="checkbox"/>	<input type="checkbox"/>	55. Tires/Pressure	<input type="checkbox"/>	<input type="checkbox"/>	89. Coolant/Filters	<input type="checkbox"/>	<input type="checkbox"/>			
13. Unusual Noise	<input type="checkbox"/>	<input type="checkbox"/>	BRAKE SYSTEM			90. Cab Filters	<input type="checkbox"/>	<input type="checkbox"/>			
14. Turbo Charger	<input type="checkbox"/>	<input type="checkbox"/>	56. Manual & Power	<input type="checkbox"/>	<input type="checkbox"/>	91. Clean A/C Condensor	<input type="checkbox"/>	<input type="checkbox"/>			
15. Intake System	<input type="checkbox"/>	<input type="checkbox"/>	57. Linkage/Control	<input type="checkbox"/>	<input type="checkbox"/>	92. A/C Check	<input type="checkbox"/>	<input type="checkbox"/>			
16. Muffler/Exhaust Systems	<input type="checkbox"/>	<input type="checkbox"/>	58. Lines/Hoses	<input type="checkbox"/>	<input type="checkbox"/>	MISCELLANEOUS					
17. High & Low Idle Speed	<input type="checkbox"/>	<input type="checkbox"/>	59. Parking Brake/Lock	<input type="checkbox"/>	<input type="checkbox"/>	93. Welds/Frames	<input type="checkbox"/>	<input type="checkbox"/>			
18. Fuel Pumps	<input type="checkbox"/>	<input type="checkbox"/>	COOLING SYSTEM			94. Exterior Condition	<input type="checkbox"/>	<input type="checkbox"/>			
19. Fuel Lines/Clamps	<input type="checkbox"/>	<input type="checkbox"/>	60. Radiator Core	<input type="checkbox"/>	<input type="checkbox"/>	95. Seat Operates/Condition	<input type="checkbox"/>	<input type="checkbox"/>			
20. Fuel Shut off System	<input type="checkbox"/>	<input type="checkbox"/>	61. Hoses/Clamps/Rad. Cap	<input type="checkbox"/>	<input type="checkbox"/>	96. Operator's Manual	<input type="checkbox"/>	<input type="checkbox"/>			
21. Fuel Throttle Linkage	<input type="checkbox"/>	<input type="checkbox"/>	62. Water Pump	<input type="checkbox"/>	<input type="checkbox"/>	97. Radio	<input type="checkbox"/>	<input type="checkbox"/>			
22. Fuel Tank	<input type="checkbox"/>	<input type="checkbox"/>	63. Fan Assembly	<input type="checkbox"/>	<input type="checkbox"/>	98. Fire Extinguisher (if equipped)	<input type="checkbox"/>	<input type="checkbox"/>			
23. Fuel Cap	<input type="checkbox"/>	<input type="checkbox"/>	64. Coolant/_____ ° F/C	<input type="checkbox"/>	<input type="checkbox"/>	FLUID ANALYSIS (VALIDATED THRU INTERNET SITE)					
24. Belts/Tensioner	<input type="checkbox"/>	<input type="checkbox"/>	65. Coolant Recovery	<input type="checkbox"/>	<input type="checkbox"/>	99. Engine	<input type="checkbox"/>	<input type="checkbox"/>			
25. Cold Starting Aids	<input type="checkbox"/>	<input type="checkbox"/>	HYDRAULIC			100. Hyd/Trans	<input type="checkbox"/>	<input type="checkbox"/>			
26. Block Heater	<input type="checkbox"/>	<input type="checkbox"/>	66. Oil Level	<input type="checkbox"/>	<input type="checkbox"/>	101. MFD					
ELECTRICAL			67. Lines/Hoses	<input type="checkbox"/>	<input type="checkbox"/>	a. Front Differential	<input type="checkbox"/>	<input type="checkbox"/>			
27. Neutral Starting Switch	<input type="checkbox"/>	<input type="checkbox"/>	68. Control/Linkage	<input type="checkbox"/>	<input type="checkbox"/>	b. Outboard Planetaries	<input type="checkbox"/>	<input type="checkbox"/>			
28. Connections	<input type="checkbox"/>	<input type="checkbox"/>	69. Oil Cooler	<input type="checkbox"/>	<input type="checkbox"/>	102. Coolant (cc 2700 kit)	<input type="checkbox"/>	<input type="checkbox"/>			
29. Battery Fluid	<input type="checkbox"/>	<input type="checkbox"/>	70. Cylinders/Valves	<input type="checkbox"/>	<input type="checkbox"/>						
30. Battery Hold Down	<input type="checkbox"/>	<input type="checkbox"/>	71. Reservoir	<input type="checkbox"/>	<input type="checkbox"/>						
31. Battery Voltage	<input type="checkbox"/>	<input type="checkbox"/>	72. Operational	<input type="checkbox"/>	<input type="checkbox"/>						
32. Battery Area Clear/Clean	<input type="checkbox"/>	<input type="checkbox"/>	73. Proper Detent	<input type="checkbox"/>	<input type="checkbox"/>						
33. Starter	<input type="checkbox"/>	<input type="checkbox"/>	74. Quick Couplers	<input type="checkbox"/>	<input type="checkbox"/>						
34. Alternator	<input type="checkbox"/>	<input type="checkbox"/>	LEAKS								
35. Wipers	<input type="checkbox"/>	<input type="checkbox"/>	75. Oil	<input type="checkbox"/>	<input type="checkbox"/>						
36. Heat/A/C Fan	<input type="checkbox"/>	<input type="checkbox"/>	76. Coolant	<input type="checkbox"/>	<input type="checkbox"/>						
37. Turn Signals	<input type="checkbox"/>	<input type="checkbox"/>	77. Fuel	<input type="checkbox"/>	<input type="checkbox"/>						
38. Lights	<input type="checkbox"/>	<input type="checkbox"/>									
39. Drain Sensing Unit	<input type="checkbox"/>	<input type="checkbox"/>									
40. Differential Lock	<input type="checkbox"/>	<input type="checkbox"/>									
41. Shutdown Override	<input type="checkbox"/>	<input type="checkbox"/>									
42. Instrumentation/ Warning Lights	<input type="checkbox"/>	<input type="checkbox"/>									
43. MFD Switch	<input type="checkbox"/>	<input type="checkbox"/>									

* Adjust valve lash if Operator's Manual scheduled interval has been reached at time of inspection.

SERVICE INSPECTIONS

HEATING VENTILATION AND AIR CONDITIONING

HOW TO MAKE SURE YOUR A/C BEATS THE HEAT

Summer's hot and muggy days can become down right comfortable with a well-maintained cab air conditioning system. Here are some ways to help your A/C system keep you cool.

- Check the drive belt. Verify proper tension and check for signs of wear.
- Clean the condenser. It's often integrated with the radiator and the oil cooler. All should be free of any debris that can build up between units; use compressed air or a power washer to remove dust between condenser fins that can reduce cooling efficiency.
- Inspect the compressor and hoses. Oil seepage from the compressor, hoses, connectors or couplings can be potential problems. Contact your Case IH dealer for suggested repair options if you detect leakage.
- Keep cab filters clean. Frequently clean both the fresh air and recirculating air filters.
- Check the evaporator drain hose. Don't let water collect in the evaporator box. Make sure the drain hose is unobstructed.
- Keep the cab airflow high. Especially in high humidity, holding the cab's fan speed higher will reduce the likelihood of the evaporator core freezing. For non Automatic Temperature Control (ATC) systems, you should change cab temperature by adjusting the temperature setting before decreasing the fan speed.
- Don't repair air conditioning systems yourself. Clean Air Act legislation requires that air conditioning systems be serviced only by personnel certified in refrigerant recovery and recycling. Let your Case IH professional do it.

Case IH dealers offer air conditioning Customized Maintenance Inspections and a full line of compressors, condensers, and other air conditioning parts to fit your exact need. Use these services and parts to help keep your air conditioning performing at its peak.

SYSTEM TYPE	INSPECT/SERVICE		COMPONENT	INSPECT/SERVICE	
1. HFC134a	<input type="checkbox"/>	<input type="checkbox"/>	1. Compressor (leakage, alignment, noise)	<input type="checkbox"/>	<input type="checkbox"/>
2. R12	<input type="checkbox"/>	<input type="checkbox"/>	2. Compressor Clutch (field coil, bearing, air gap)	<input type="checkbox"/>	<input type="checkbox"/>
3. Retrofitted	<input type="checkbox"/>	<input type="checkbox"/>	3. Compressor Belt (condition, tension)	<input type="checkbox"/>	<input type="checkbox"/>
TROUBLESHOOTING SYMPTOM:					
4. No Heat	<input type="checkbox"/>	<input type="checkbox"/>	4. Condenser (clear of dust/debris, leaks)	<input type="checkbox"/>	<input type="checkbox"/>
5. Poor Heat	<input type="checkbox"/>	<input type="checkbox"/>	5. Receiver/Dryer	<input type="checkbox"/>	<input type="checkbox"/>
6. No A/C	<input type="checkbox"/>	<input type="checkbox"/>	6. A/C Hoses		
7. Poor A/C	<input type="checkbox"/>	<input type="checkbox"/>	a. Suction	<input type="checkbox"/>	<input type="checkbox"/>
8. No Defrost	<input type="checkbox"/>	<input type="checkbox"/>	b. Discharge	<input type="checkbox"/>	<input type="checkbox"/>
9. Air From Wrong Outlets	<input type="checkbox"/>	<input type="checkbox"/>	c. Condenser to Dryer	<input type="checkbox"/>	<input type="checkbox"/>
10. No Temperature Control	<input type="checkbox"/>	<input type="checkbox"/>	d. Chassis Liquid	<input type="checkbox"/>	<input type="checkbox"/>
11. Improper Blower Operation	<input type="checkbox"/>	<input type="checkbox"/>	e. Cab Suction	<input type="checkbox"/>	<input type="checkbox"/>
12. Interior Noise	<input type="checkbox"/>	<input type="checkbox"/>	f. Cab Liquid	<input type="checkbox"/>	<input type="checkbox"/>
13. Exterior Noise	<input type="checkbox"/>	<input type="checkbox"/>	7. A/C Pressure Switches		
14. Interior Leak	<input type="checkbox"/>	<input type="checkbox"/>	a. Low-Pressure Switch	<input type="checkbox"/>	<input type="checkbox"/>
15. Exterior Leak	<input type="checkbox"/>	<input type="checkbox"/>	b. High-Pressure Switch	<input type="checkbox"/>	<input type="checkbox"/>
16. Odor	<input type="checkbox"/>	<input type="checkbox"/>	8. Evaporator Box	<input type="checkbox"/>	<input type="checkbox"/>
17. Error Codes (if applicable)	<input type="checkbox"/>	<input type="checkbox"/>	9. Evaporator Seals	<input type="checkbox"/>	<input type="checkbox"/>
18. Other: _____	<input type="checkbox"/>	<input type="checkbox"/>	10. Evaporator Capillary Tube	<input type="checkbox"/>	<input type="checkbox"/>
WHEN DOES SYMPTOM OCCUR:					
19. Always	<input type="checkbox"/>	<input type="checkbox"/>	11. Evaporator Condensate Drain Tube	<input type="checkbox"/>	<input type="checkbox"/>
20. Sometimes	<input type="checkbox"/>	<input type="checkbox"/>	12. Odor	<input type="checkbox"/>	<input type="checkbox"/>
21. When Hot	<input type="checkbox"/>	<input type="checkbox"/>	13. Thermostat Expansion Valve	<input type="checkbox"/>	<input type="checkbox"/>
22. When Cold	<input type="checkbox"/>	<input type="checkbox"/>	14. Thermostat Switch	<input type="checkbox"/>	<input type="checkbox"/>
23. When Engine Is Started	<input type="checkbox"/>	<input type="checkbox"/>	15. Heater Control Valve	<input type="checkbox"/>	<input type="checkbox"/>
24. When Engine Is Warming Up	<input type="checkbox"/>	<input type="checkbox"/>	16. Heater Hoses & Clamps	<input type="checkbox"/>	<input type="checkbox"/>
25. When Idling	<input type="checkbox"/>	<input type="checkbox"/>	17. Air Filters		
26. At High Engine RPM	<input type="checkbox"/>	<input type="checkbox"/>	a. Fresh	<input type="checkbox"/>	<input type="checkbox"/>
27. During Acceleration	<input type="checkbox"/>	<input type="checkbox"/>	b. Recirculation	<input type="checkbox"/>	<input type="checkbox"/>
28. While In Motion	<input type="checkbox"/>	<input type="checkbox"/>	18. Cab Blower	<input type="checkbox"/>	<input type="checkbox"/>
			19. A/C Fluorescent Dye	<input type="checkbox"/>	<input type="checkbox"/>
			20. Refrigerant Charge	<input type="checkbox"/>	<input type="checkbox"/>
			21. Clean and Flush System	<input type="checkbox"/>	<input type="checkbox"/>

FILTERS

LUBE FILTRATION SYSTEMS

To meet the performance demands of today's tough off-road environments, your equipment generates more usable horsepower than ever before. Tighter tolerances, higher temperatures, and severe duty cycles are driving the requirement for high quality filtration and increased durability without sacrificing filter life. Today's low-emission engine designs make engine filtration extremely critical, especially particles in the 5-10 micron range, which are most damaging to modern engines.

While the costs for repairing equipment breakdowns are normally high, they are often minuscule compared to those associated with delayed harvests or missed project completion deadlines. Don't jeopardize productivity by using "will-fit" filtration. Case IH lube filters are designed specifically for your equipment. They're guaranteed to ensure peak performance while providing maximum protection for your investment.

- **2-STAGE DESIGN.** 2-stage design removes the smaller-sized (5-15 micron) particles that can cause the most damage in today's high-performance (emissions) engines.
- **SUPERIOR MEDIA.** Case IH filters are designed to trap more of the small contaminants that are most damaging to diesel engines. The media is uniformly resin-impregnated and heat-cured to provide efficient filtration while resisting the effects of moisture. The media used in many of our newer filters combine microglass and cellulose fibers for doubled efficiency over standard filters.
- **PLASTISOL ADHESIVE.** Case IH filters use plastisol, a high quality adhesive, to uniformly bond the filter element to the end caps. Plastisol adhesive keeps the filter media from bunching and rupturing.
- **RUBBER SEALS.** Many filter manufacturers use cardboard seals at the ends of the filters; cardboard seals can deteriorate or leak. Case IH filters use a thin piece of rubber which provides a tight, even seal at the base of the filter. It prevents unfiltered oil from bypassing the filter media and reentering your system.
- **METAL END CAPS.** Solid metal end caps provide additional strength to the filter element. Metal is superior to the cardboard that many manufacturers use.
- **OEM SPECIFIED.** Case IH filters meet all Case IH specifications. When you buy a Case IH filter, you're buying the confidence that Case IH engineers have placed in the filter to protect your engine, and save you repair costs.



◀ 'Stacked-disc' secondary media removes what "will-fits" can't.

◀ Primary synthetic media provides high-efficiency filtration.

CUSTOM-DESIGNED FILTRATION MEDIA

- Synthetic
- Cellulose
- Blends
- Stacked Disk

PATENTED COMBINATION FULL-FLOW/ BYPASS FILTRATION PRODUCTS

GUARANTEED TO MEET OEM SPECIFICATIONS

OPTIMIZED FILTRATION PERFORMANCE IN CAPACITY (LIFE), EFFICIENCY (CLEAN- LINESS), AND RESTRICTION TO FLOW

- Minimizes progressive wear
- Reduces bearing and ring wear
- Excellent sludge removal
- Filters oil sooner during cold starts



SELECTING FLUIDS

ENGINE OIL

Engine oil change intervals recommended in your Operator's Manual are based on the use of Case IH No. 1 engine oil. Case IH No. 1 engine oil has been formulated specifically for Case IH tractors with diesel engines without the use of any highly advertised "performance additives."

Under severe operating conditions, such as light load cold temperature operation and extreme load high temperature operation, the engine oil should be changed at more frequent service intervals.



MAGNUM AND STEIGER TRACTOR ENGINE OIL CAPACITY

Tractor Model	Engine Oil Capacity (Gallon / Liter)
8910, 8920, 8930, 8940, 8950	5.5g/21l
MX180, MX200, MX220, MX240, MX270	5.5g/21l
MX210, MX230, MX255, MX285	5.5g/21l
Magnum 215, 245, 275, 305, 335	5.5g/21l
9310, 9330	5.5g/21l
9350	9.7g/36.7l
9370, 9380, 9390	10.2g/38.6l
STX275	6.3g/23.8l
STX325	7.25g/27.4l
STX375, STX425, STX450, STX500	13g/49.2l
STX440	12g/45.4l
Steiger 280	6.3g/24l
Steiger 335	7.3g/27.4l
Steiger 330, 380, 430	7.3g/28l
Steiger 385, 435, 485	8.2g/31l
Steiger 480-530	13g/49l
Steiger 535	13g/49l

DIESEL FUEL

Use a good grade of fuel which meets SAE/ASTM EN 590 or equivalent. The use of biodiesel blends is approved for Case IH engines up to B5 (5% blend ratio).

HYDRAULIC AND TRANSMISSION FLUID

Case IH Hy-Tran Ultra is the very finest hydraulic-transmission fluid available and the only brand guaranteed to give your product complete protection. The Hy-Tran fluid in a brand new tractor has been dyed (green or red) to assist in leak detection during the manufacturing process. Replacement Hy-Tran does not have this dye. Change your Hy-Tran fluid as recommended in the Operator's Manual supplied with your tractor.

OIL VISCOSITY/TEMPERATURE USAGE RECOMMENDATION

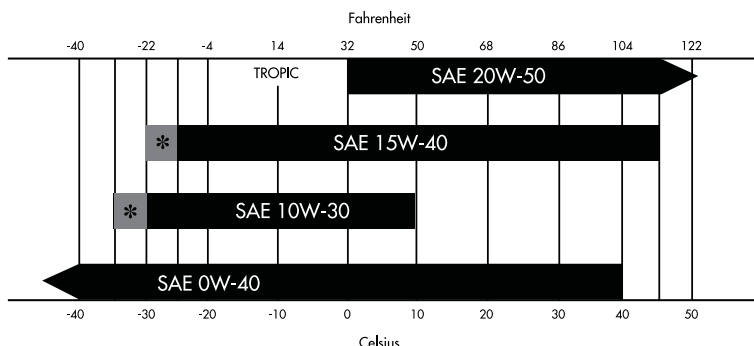

*Use of an engine oil heater, or an engine coolant heater, is required in gray area.



DAILY SERVICE

SERVICE SHOULD BE PERFORMED EVERY 10 HOURS OR DAILY (WHICHEVER COMES FIRST) TO KEEP YOUR CASE IH TRACTOR RUNNING AT ITS BEST.



MAGNUM TRACTORS

Daily service functions can be performed in a single location to get you to the field faster each day.

- Check engine oil level
- Check hydraulic/transmission oil level
- Check engine coolant reservoir level
- Check fuel level
- In severe dusty or wet conditions, grease rear hitch & front axle every 10 hours; otherwise every 300 hours

50 hours (or weekly) – Drain water from fuel filter drain plug

STEIGER TRACTORS

Daily service required:

- Check engine oil level
- Check hydraulic/axle oil level
- Check transmission oil level
- Check coolant level (reservoir & deaeration tank)
- Check fuel level
- 50 hours (or Weekly)
 - Drain water from fuel filter drain plug and fuel tank
 - Grease articulation/oscillation hinges, articulation & three point hitch (TPH) cylinders, and center link fittings

Note: Magnum and Steiger tractors require daily, weekly, and scheduled maintenance intervals to keep equipment in top performing condition. Although service requirements for Case IH tractors may be similar, please refer to the equipment's Operator's Manual for lubrication information, service intervals, and component locations.



SERVICE POINTS

ENGINE OIL AND COOLANT FILTERS

Vertically mounted engine oil filters permit easy, clean, no-spillage service. Case IH coolant filters are specially designed to protect the cooling system from contamination and condition the coolant to prevent erosion and cavitation.

Magnum tractors

- Engine oil and filter – 300 hours
- Coolant filter – 600 hours
- Coolant and conditioner – 2100 hours

Steiger tractors

- Engine oil and filter – 500 hours
- Coolant (check SCA level) – 500 hours
- Coolant filter – 1500 hours
- Coolant (drain & flush) – 6000 hours ▶



RADIATOR/COOLERS

Clean the radiator, hydraulic oil coolers, fuel cooler and air conditioning equipment as required by conditions during regular service.



FUEL FILTERS

Fuel filters protect the fuel system from dirt and water damage. Use clean fuel, keep the fuel tank full to prevent water condensation, and drain the water separator section at regular service intervals.

Magnum tractors

- Engine fuel filters – 600 hours

Steiger tractors

- Engine fuel filters – 500 hours
(or when service icon is displayed) ▶



TRANSMISSION, HYDRAULIC, AND AXLE FILTERS

Magnum tractors

The combined transmission and hydraulic systems are protected from contamination by two high performance spin-on filters on the right hand side of the transmission.

- Transmission oil and filters – 1500 hours

Steiger tractors

The transmission and hydraulic systems are independent. The hydraulic system shares its circuit with the axle lube system.

- Hydraulic oil and filter – 1500 hours
- Axle lube filter – 1500 hours

SERVICE POINTS

ENGINE AIR FILTERS

Clean the primary filter when notified by tractor instrumentation to maintain engine power and performance. The secondary (inner) filter element should only be replaced. Do not attempt to clean the filter element.

Magnum Series Tractors

Primary & secondary engine air filters

- As required (recommend 1200 hours or annually)

Steiger Series Tractors

Primary & secondary engine air filters

- 1500 hours



BATTERIES

Current models of Case IH equipment use maintenance-free batteries. Terminals should be cleaned as necessary. On older models without maintenance-free batteries, clean terminals as necessary and check electrolyte levels before and after winter storage.

CAB CLEAN AIR AND RECIRCULATION FILTERS

Proper heating and cooling performance depends on proper air flow through the cab clean air and recirculation filters. Recirculation air filters should be cleaned with mild soap and water as required by conditions during regular service. Clean cab air recirculation filters improve air conditioning system efficiency and make cab comfort easier to maintain.

Note: Be sure cab recirculation filters are not blocked. A clear flow path must be maintained for optimum cab comfort.



◀ Magnum Tractors

The clean air filter is located below the cab door. The recirculation filters are located on both sides of the operator's seat near the floor mat.

- Cab air and recirculation filters – As required (recommended 1500 hours)

◀ Steiger Tractors

The clean air filter is located underneath the left rear corner of the cab. The recirculation filter is located directly behind the operator's seat.

- Cab air & recirculation filters – 1500 hours



FUSES & RELAYS

Magnum Tractors

Engine circuit protection fuses are located inside the engine service door below the engine air filter assembly. The tractor circuit fuses and relays are located below the floor mat behind the operator's seat.

Steiger Tractors

All fuses and relays are located under the removable panel to the left of the operator's seat.

PERFORMANCE HIGHLIGHTS

MAGNUM SERIES TRACTORS PERFORMANCE ITEMS



◀ SUSPENDED MFD AXLE

Magnum tractor models have an optional suspended MFD axle available. The suspended axle keeps the MFD drive wheels on the ground for optimum traction. This keeps the tractor stable under the variety of conditions tractors encounter on a regular basis. The suspended axle also provides a smoother ride over rough terrain.



▲ DUAL SPEED PTO

Magnum tractor models offer a dual speed PTO with interchangeable 540 and 1000 (large and small) speed shafts. The dual speed PTO capability offers connection to a variety of implements without the need to change tractors. The PTO shafts interchange easily, requiring only small hand tools.



▲ TRUE GROUND SPEED SIGNAL

Magnum and Steiger tractor models have an in-cab true ground speed signal socket. Using the socket simplifies connection of the true ground speed signal to spraying and planting systems. Order cable part number 324847A2.



▲ FOOT THROTTLE

Magnum tractor has an optional foot throttle available that frees the operator's hands for other functions. A foot throttle can be a valuable enhancement for a loader tractor. Steiger tractor models have an optional decelerator pedal available.



◀ DRAWBAR POSITIONING/ PTO DRIVELINE ADJUSTMENT

When switching PTO shaft speeds on Magnum models, you must reposition the drawbar to meet SAE dimensions. Failure to adjust the drawbar length could result in damage to either the tractor or the implement PTO drive line. Use the implement PTO driveline height adjustment to ensure a minimum vertical angle of the implement PTO shaft. The horizontal distance from end of shaft to center of drawbar pin should be:

Shaft	Distance
540	14"
Small 1000	16"
Large 1000	20"

PERFORMANCE HIGHLIGHTS

HIGH-CAPACITY DRAWBAR

A high-capacity drawbar option is available for applications where extra heavy drawbar loads are expected. The high-capacity drawbar should be used for applications like front folding planters, liquid manure wagons and large grain carts. Three swing positions, one on each side of center, are obtainable by moving bolts which extend up through the drawbar hanger on both sides of the drawbar. Six drawbar mounting positions are available just like the standard drawbar. The heavy-duty drawbar allows equal angle hitching when necessary. The heavy-duty drawbar is optional and has a vertical tongue load rating of 4990 kg (11,000 lbs). The "auto pin" clevis is standard. Heavy Duty Drawbar kit is available for all Magnum tractors.



- Drawbar kit part number - 435788A1 (includes the auto-pin hitch and mounting hardware).
- Drawbar part number - 426511A1.



MOTOR RETURN AND POWER BEYOND

An optional motor return kit mounts to the top of the couplers on the left side. Motor return port installation reduces back pressure in hydraulic circuit return lines. This results in more efficient hydraulic system operation. The motor return consists of one return coupler (3/4") and one case drain coupler (1/4"). The motor return housing is the same housing used for power beyond applications without the lines, connections, and couplers required for power beyond functions.

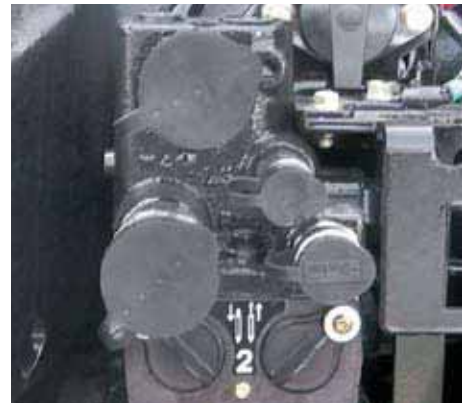

NOTE: The motor return kit is required for some planting and seeding implement applications. Power beyond provides a hydraulic supply port, a low pressure return port, a sensing port, and a case drain coupler (ported to reservoir). Power beyond provides a versatile connection point for specialty hydraulic applications.

IMPORTANT: The case drain coupler should only be used for low flow, case drain applications. Transmission lube pressure could be adversely affected, if the case drain coupling is used for other applications.

Coupler Tips: For maximum performance, use only ISO tips.



ELECTRONIC SERVICE TOOL (EST)

THE POWER OF MORE INFORMATION

CAN SYSTEM PUTS TODAY'S TECHNOLOGY TO WORK FOR YOU

Case IH service technicians now use an Electronic Service Tool (EST) to service Case IH tractors. Tractors equipped with a **Controller Area Network (CAN)**, allow the tractor systems to communicate on one network.

- Provide Information to the Operator
- Improve Tractor Operation
- Enhance Tractor Performance
- Prevent System Failures
- Provide Quick and Accurate Troubleshooting

Service technicians connect the Electronic Service Tool into the tractor CAN system to communicate using the CAN network. Fault based diagnostics are used to quickly identify problem circuits. Detailed photographs, diagrams and component locators on the EST screen provide complete information about related wiring and connectors. Repairs can be made quickly, assuring maximum productivity. In addition to service diagnostics, the EST can be used to download new software to upgrade the functions performed by the controller networks. It can also be used to change the default transmission gears.

Consider several examples of how controllers and other devices within the CAN work together. As the tractor moves through the field, the controllers in the CAN system continually check a variety of inputs:

- Operator Commands
- Engine Torque
- Gear Selection
- Tractor Speed
- Wheel Slip
- Hitch Position

As conditions vary, this information is used by the system to adjust engine power to the transmission. The transmission responds to commands from the operator to complete functions that previously required individual actions by the operator. The operator's time is available to make corrections in the field. As the operator moves the hand throttle lever or signals other operations, the tractor identifies the change and sends the new command to the required systems via the CAN system. Case IH tractors are designed as a platform for evolving technology to provide more usable information.

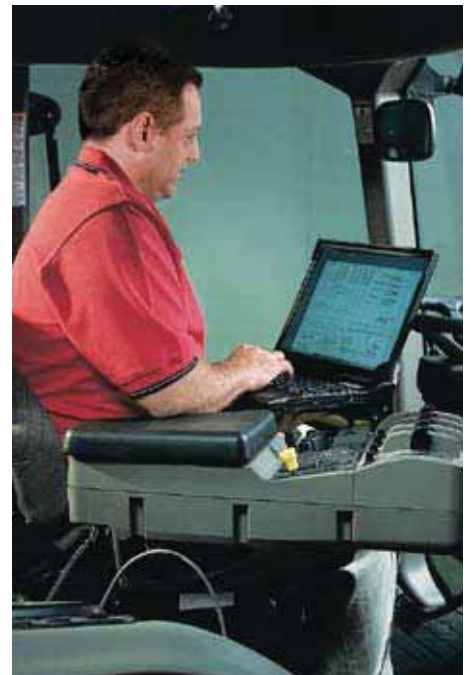

EZ-GUIDE® PLUS LIGHTBAR



EZ-GUIDE 250 ADVANTAGES

- Radar speed output
- Output GPS data to other external devices (NMEA format)
- Simple to install RAM mount
- Rugged cast aluminum housing for reliable operation
- All agricultural climates & field conditions
 - Operational temperature 32 °F to 122 °F (0 °C to 50 °C)
 - Operating voltage 9 to 16 V DC

EZ-GUIDE 500 ADVANTAGES

- Add EZ-Steer® 500 for hands-free assisted steering.
- Upgrade to 6-8 inch pass-to-pass accuracy by purchasing the AG15 antenna kit.
- Optional cabling available for radar speed and NMEA output.
- Mounts using a simple-to-install RAM mount.
- Rugged cast aluminum housing for reliable operation and durability.
- Languages available: English, Spanish, Portuguese, French, and many more.



PRECISION FARMING

To support both your new purchase and your existing fleet, Case IH has a number of Precision Farming systems available for use on your Case IH equipment and/or most other competitive brands.

The EZ-Guide® 250 Lightbar is the entry level into precision farming, add EZ-Steer for the most basic assisted steering package.

The EZ-Guide® 500 Lightbar has added functionality and accuracy upgrade options over the 250 model. The EZ-Guide 500 can be used with EZ-Steer systems for assisted steering, can be used with EZ-Boom for spraying and planter control, and can also be combined with a full Autopilot platform system.

The flagship Field Manager Display is the advanced display option for Autopilot systems. This display has logging and mapping capability but also has numerous enhanced functions such as rate and flow control for multiple applications, such as spraying, planting and anhydrous ammonia applications.

For your convenience Case IH has carefully selected and made available a number of bundled EZ-Steer and Autopilot system options. Model specific bracket and platform kits are available for all the most popular brands of equipment, Case IH is unique in that it offers you the opportunity to enter the precision farming arena, safe in the knowledge you can grow and develop your system adding/adapting any previously purchased system components. The Case IH systems fully complement the latest factory installed options from Case IH and there is a solution to suit most agricultural requirements and budgets.

With inputs costs spiraling to all time highs, there has never been a better time to discuss with your local Case IH dealer how one of our Case IH precision farming accessories could be utilized on your farming enterprise.

Why not use the cost savings calculator available on www.putyourfarmonthemap.com to find out how quickly you can recover your initial investment?

For more information visit www.putyourfarmonthemap.com or visit your local Case IH Dealer.



AgGPS® EZ Products

EZ-Guide® 250	ZTN92000-20
Optional AG15 Antenna	ZTN92010-00
EZ-Guide® 500	87298853
Optional	ZTN66030-00

AgGPS® EZ-Steer® 250 System
DGPS 6" - 8" P2P Accuracy

EZ-Steer® 250 System includes:

EZ-Guide® 250	ZTN92000-20
AG15 Antenna	ZTN92010-00
EZ-Steer® 500 w/ T2	ZTN62000-50
EZ-Guide® 250 CAN Cables	ZTN65536

P/N ZTN92900-20

Calculate your savings by visiting www.PutYourFarmOnTheMap.com

RIDE, TRACTION & PERFORMANCE

GROSS VEHICLE WEIGHT

Maximum gross weight - A tractor's maximum gross weight is referred to as the combined static weight of the tractor and any added ballast. This value must not exceed the rating of the ROPS structure or the maximum gross vehicle weight as specified in the Operator's Manual. When adding ballast to a tractor, the tractor should be ballasted as light as possible to minimize soil compaction and still maintain performance.

Many tire manufacturers are recommending cast iron weights. If liquid ballast is used, Case IH requires it be placed in the inside duals only if the wheels are spacer band type. Flange style duals or hub style duals may be lightly filled. Spacer band duals should never have liquid ballast installed in the outside dual wheel.

TIRE INFLATION

Radial tires achieve their high level of tractive performance as a result of the high contact area between the rubber and the soil.

Proper adjustment of radial tire pressure means using the correct tire inflation pressure to support the static load carried by the tire and maintaining the high contact area between the tire and soil.

A tire can be inflated to safely support a wide range of loads.

- An 18.4R42 tire used as a dual, supports approximately 3200 lbs. of static load when inflated to 8 PSI
- An 18.4R42 tire will support 6950 lbs. when inflated to 24 PSI

In both instances, the tire deflects approximately the same amount. This is known as "Rated Deflection" of the tire. When the Rated Deflection is correct, the tire achieves its best performance.

The correct tire pressure for a given tractor is found by weighing the unit and then dividing the weight per axle by the number of tires. This weight is then compared to the values on the Tire Inflation vs. Weight Table to find the correct tire pressure. Tire Inflation vs. Weight Tables should be used for proper inflation pressures.



Matching the tractor to the load

Your tractor has been designed for continuous field operation at the rated horsepower while traveling at a speed of 5 mph or faster. If the engine lugs continuously at slow speeds, you can be sure that the load is not correctly matched to the tractor. This could result in damage to the tractor drive train as well as wasted fuel, increased tire wear, and soil compaction.

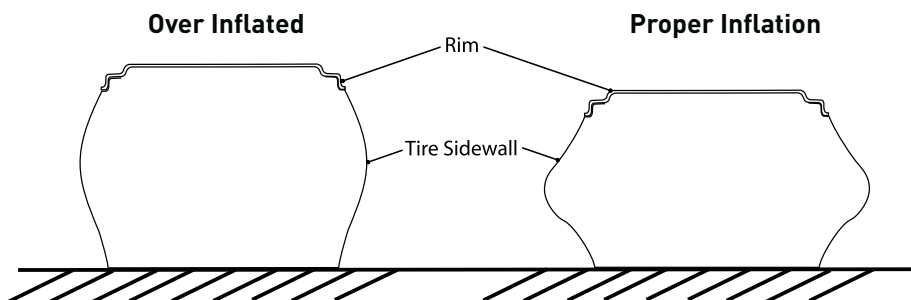

MAGNUM SERIES TRACTORS

DEFINITIONS

Rolling Circumference - Rolling circumference is the distance a tire travels in one revolution.

Interaxle Ratio - On all MFD tractors both the front and rear tires do the work. Since the front tires are smaller than the rear tires, the front tires must rotate faster to travel the same distance as the rear. The mechanical gear combination used to allow the front axle to move the tires at a faster speed is referred to as the interaxle ratio. The tractor manufacturer establishes the interaxle ratio.

Tall, wide, soft radial tires provide:

- The best traction.
- The best ride.
- The least amount of maintenance required to control a powerhop condition.



MFD DUAL WHEEL FIELD TEST RESULTS

The University of Nebraska conducted field tests in the summer of 1999 to compare the effect of traction on tractors equipped with and without front dual wheels. Results showed that when pulling a drawbar implement, generally a 65/35 rear/front weight split had the best tractive efficiency with either single or dual front wheels. Hitch mounted implements generally performed best with a 60/40 rear/front weight split. The test emphasizes the importance of proper ballasting.

During tractor ballasting, pay attention to:

- The front to rear weight split on the tractor
- Pounds of weight per PTO hp and drawbar hp
- Tire load/inflation values

Proper ballasting minimizes compaction and enhances tractor performance. Front duals increase the tire-to-ground contact area and reduce the ground contact pressure under the front axle. The tractor used for the field test was equipped with 520/85R46 rear and 480/70R34 front tires. With these tires, the use of front duals increases the tire-to-ground contact area by 25%. Lower air pressure (see Load/Inflation Charts) improves the tire footprint, while reducing the tire to ground contact pressure, and compaction in the field.

Ground Pressure Diagram

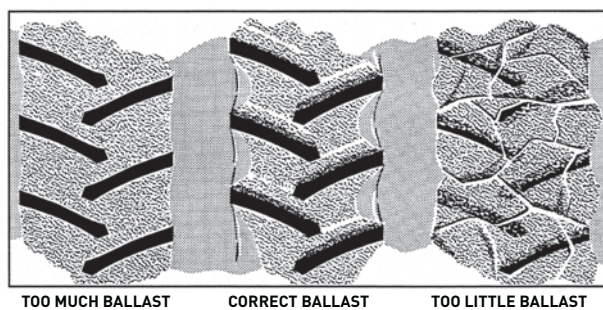
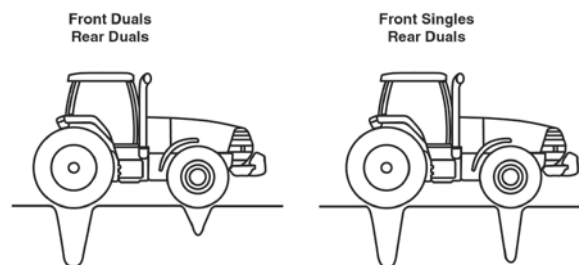

◀ EASY BALLASTING OPTIONS

Two front weight frames with tow pin hole and front weights are available. The weight frames increase front end vehicle weight and the weights wrap under the chassis providing greater ground clearance. The front wheels turn behind the weights and frame for increased visibility and tighter turning radius.

Suitcase weights are available, each weighing 45 kg (100 lb)

- when using large weight frame, a maximum of 18 weights can be installed
- when using small weight frame, a maximum of 10 weights can be installed

MAGNUM TRACTOR MFD INTERAXLE RATIO

Tractor Model	MFD Axle Manufacturer	MFD Interaxle Ratio
7110, 7120, 7210, 7220, 8910, 8920	Standard MFD Axle	1.330
7130, 7140, 7150, 7230, 7240, 7250, 8930, 8940, 8950	Standard MFD Axle	1.323
7210, 7220, 8910, 8920	Specialty MFD Axle	1.463
7230, 7240, 7250, 8930, 8940, 8950	Specialty MFD Axle	1.454
MX180, MX200, MX210, MX220, MX230	Standard MFD Axle	1.323
MX210, MX230	Specialty MFD Axle	1.455
MX210, MX230, MX240, MX255, MX270	Heavy Duty MFD Axle	1.323
MX285	Dana Heavy Duty MFD Axle	1.325

LEAD/LAG

The relationship between the front and rear tires is referred to as Lead/Lag and is stated as a percentage. Case IH has established a Lead/Lag range that provides the operator with acceptable tire wear, front tire steering, and front tire pulling power. Any tire combination that falls within this range is acceptable. Lead/Lag percentages can be calculated using the formula:

$$\frac{(\text{Rolling Circum. of Front Tire} \times \text{Interaxle Ratio}) - \text{Rolling Circum. of Rear Tire}}{\text{Rolling Circum. of Rear Tire}} \times 100 = \text{Lead/Lag \%}$$

TIRES AND TRACTOR PERFORMANCE

To optimize tractor performance, tires should be selected to suit the intended application. Key options like tire size and cast weight packages, combined with proper tire pressure, determine actual tractor performance.

FRONT TIRE SELECTION

Choose the largest front tire or front dual option with the highest weight-carrying capacity that matches the row spacing. Selection of a larger tire results in reduced compaction and permits heavier loads on the front axle without exceeding the tire load-carrying capacity.

REAR TIRE SELECTION

Choose rear tires that are large enough to carry the total ballasted weight of the tractor with an inflation pressure in the 6 - 14 psi range. Larger tires require less inflation pressure to support a given axle load than narrow tires do. Use only approved tire combinations. The Lead/Lag should be between 0 - 5%, with a value of 1 - 3% being best. Negative Lead/Lag is not recommended.

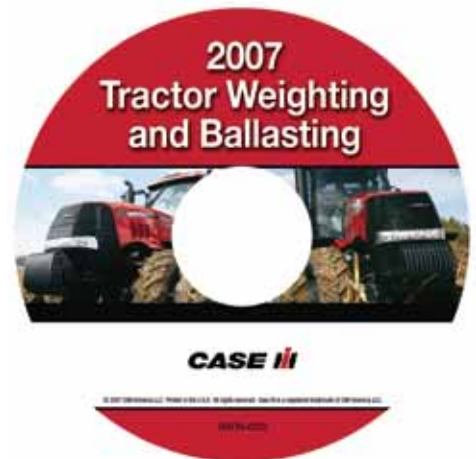

▲ BALLASTING CD

Case IH offers a variety of CD based tools to assist in preparing your tractor for the field. Contact your dealer for more information. Part number CIHT76-07CD.

RIDE, TRACTION & PERFORMANCE

STEIGER 4WD TRACTORS

Tire manufacturers have found practices and procedures developed for bias ply tires may actually reduce the performance of radial ply tires. Minor adjustments in the tractor weight split (front/rear), ballast, and tire inflation pressure can dramatically improve performance of the tractor.

Proper weight split, ballast, and tire inflation can:

- Improve Traction
- Reduce Compaction
- Reduce Occurrence of Power Hop
- Increase Powertrain Life
- Reduce Tire Wear
- Improve Ride

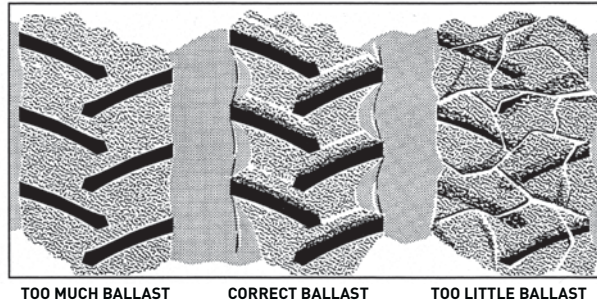

FRONT & REAR SUITCASE WEIGHTS

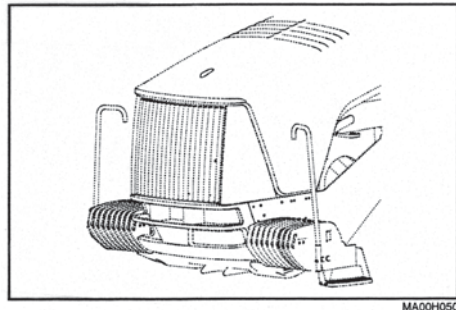

FRONT FRAME WEIGHTS

Front suitcase weights can be mounted on the front of the tractor with a weight hanger. A maximum of 18 suitcase weights at 45 kg. (100 lb) each can be installed, depending on the application, tractor static weight split and soil conditions.

REAR FRAME WEIGHTS

Suitcase weights can also be mounted on the rear of the tractor with a weight frame. However, rear suitcase weights cannot be used if the tractor is equipped with a three point hitch.

A maximum of 14 suitcase weights at 45 kg (100 lb) each can be installed depending on implement application, front mounted equipment, tractor static weight split and soil conditions.

Assembly weight:

Weight frame = 468 kg (1032 lb)

Frame + 14 suitcase weights = 1166 kg (2571 lb)

The entire weight assembly can be removed from the tractor by removing two bolts and using an overhead hoist attached to the lifting bracket rear hole (1) on each side. See your dealer for more information.

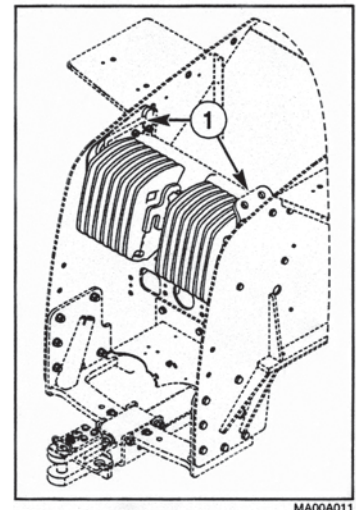

IMPORTANT: Total tractor static weight with all equipment and ballast must never be more than the recommended operating weight. See Maximum Recommended Operating Weight in Operator's Manual.

BALLASTING 4WD TRACTORS - DRAWBAR APPLICATIONS

For tractors used in drawbar work only: generally these tractors are not equipped with a 3-point hitch or PTO and are used to pull standard pull type implements such as disks, chisel plows, field cultivators, rippers, etc. Tractors in this type of application should be ballasted with no more than 55% of the weight on the front axle.

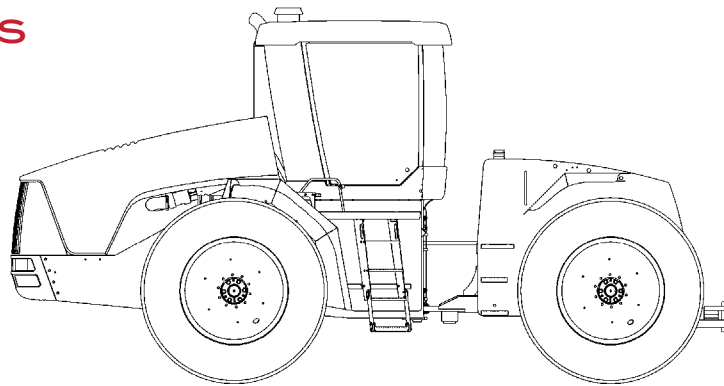

Front 55% Rear 45%
Drawbar Towed High Draft Implements

BALLASTING 4WD TRACTORS - 3-POINT HITCH APPLICATIONS

For tractors used for 3-point hitch work only: tractors in this type of application should be ballasted with 60% of the weight on the front axle.

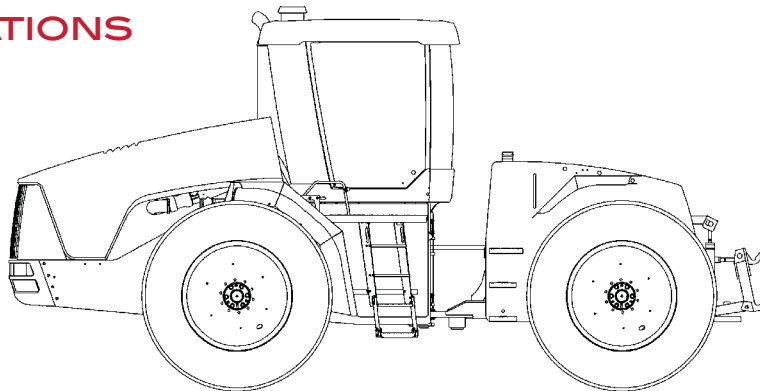

Front 60% Rear 40%
Hitch Mounted Implements

BALLASTING 4WD TRACTORS - HIGH VERTICAL LOAD APPLICATIONS

For tractors used with scrapers or other implements with high vertical loads: tractors in this type of application should be ballasted with 65% of the weight on the front axle. This should allow the tractor to achieve a 50/50 weight split while operating under load. If the tractor is equipped with a 3-point hitch or PTO, it may not be possible to achieve this level of balance and still stay within the maximum operating weight limitations. If this is the case, adjust as close as possible to the 65%-35% specification, and stay within the maximum operating weight limitation.

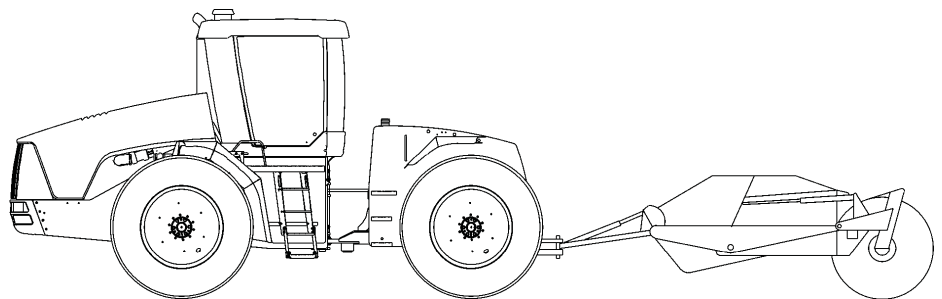

Front 65% Rear 35%
Implements with Heavy Vertical Drawbar Loads

RIDE, TRACTION & PERFORMANCE

MAGNUM TRACTORS—TIRE LOAD AND INFLATION

The inflation pressures are based on cold inflation pressure recommended by the Tire and Rim Association Inc.

How to Use the Load and Inflation Charts:

1. Determine the ballasted tractor front axle weight and tractor rear axle weight.

Note: If using fully mounted or high vertical drawbar implements, add the weight of the implement to the rear weight (refer to implement manual for weight).

2. Find the appropriate chart (Front Singles or Duals, Rear Singles, Duals or Triples).
3. Find tire size and correct rating.
4. Follow the row across to the first weight that is above your tractor (front or rear) axle weight.
5. Follow the column up to find the minimum recommended tire inflation pressure.

Note: Never exceed the load capacity for a particular tire. To obtain more load capacity, use duals or change to a different tire.

Note: Never exceed the inflation pressure for a particular tire. The last number in the chart is the maximum inflation pressure for that particular tire.

Note: Increase tire pressures 2 to 4 PSI over those stated in the chart for any of the following conditions:

- If tire pressures are not checked daily
- Sharp turning and/or braking will be encountered
- In-Furrow operation (Furrow tire only)
- Side hill operation

STEIGER TRACTORS—TIRE PRESSURE FOR MAXIMUM TIRE LOAD AT RATED INFLATION

To reach the best tire pressure and load capacity, scale weigh the front and rear axle of the tractor.

DETERMINE PROPER BALLAST WEIGHT SPLIT.

- 60% Front/40% Rear - Tractor used with hitch mounted implements.
- 55% Front/45% Rear - Tractor used with drawbar towed high draft implement.
- 65% Front/35% Rear - Tractor used with high vertical drawbar loads.

See Tractor Ballast information for additional information.

DETERMINE CORRECT STATIC LOAD DISTRIBUTION AND TIRE PRESSURE FROM CHART.

Example: Tractor used with standard drawbar implements, 18.4R-42 dual tires and a full tank of fuel. Desired weight split = 55% Front/45% Rear.

- Front Weight of Tractor = 14,000 lb (6350 kg)
- Rear Weight of Tractor = 9392 lb (4260 kg)
- Total Weight of Tractor = 23,392 lb (10610 kg)

DETERMINE WEIGHT DISTRIBUTION BY DIVIDING FRONT AND REAR WEIGHT BY TOTAL WEIGHT.

Tractor Weight Distribution =

- 59.8% Front Axle
- 40.2% Rear Axle

ADJUST THE WEIGHT DISTRIBUTION BY ADDING 2000 LB (907 KG) WEIGHT TO THE REAR WHEELS.

Adjusted Weight:

- Front weight = 14,000 lb (6350 kg)
- Rear weight = 11,392 lb (5167 kg)
- Total weight = 25,392 lb (11 517 kg)
- Total weight distribution =
 - 55.1% Front Axle
 - 44.9% Rear Axle

Front Static Load - Weight divided by number of tires.

- $14,000 \text{ lb} / 4 = 3500 \text{ lb}$ ($6350 \text{ kg} / 4 = 1588 \text{ kg}$)

Front Chart: 18.4R-42 Dual Tires -

- 3500 lb = 9 PSI (1588 kg = 62 kPa)

Rear Static Load - Weight divided by number of tires.

- $11,392 \text{ lb} / 4 = 2848 \text{ lb}$ ($5167 \text{ kg} / 4 = 1292 \text{ kg}$)

From Chart = 18.4R-42 Dual Tires -

- 2848 lb = 7 PSI (1292 kg = 48 kPa)

LOAD/INFLATION CHART - CONVENTIONAL SIZE RADIAL TIRES

Tire Size	Inflation Pressure	6 PSI	8 PSI	10 PSI	12 PSI	14 PSI	16 PSI	18 PSI	20 PSI	22 PSI	24 PSI	26 PSI	28 PSI
14.9R46	Single lbs.	2270	2680	3080	3420	3740	3960	4300	4540	4800	5080	5360	5520
	Dual lbs.	2000	2360	2710	3010	3290	3480	3780	4000	4220	4470	4720	4860
	Triple lbs.	1860	2200	2530	2800	3070	3250	3530	3720	3940	4170	4400	4530
18.4R38	Single lbs.	3000	3520	3960	4400	4800	5200	5680	6000	6400	6600	6950	7400
	Dual lbs.	2640	3100	3480	3870	4220	4580	5000	5280	5630	5810	6120	6510
	Triple lbs.	2460	2890	3250	3610	3940	4260	4660	4920	5250	5410	5700	6070
18.4R42	Single lbs.	3080	3740	4180	4680	5080	5520	6000	6400	6600	6950	7400	7600
	Dual lbs.	2710	3290	3680	4120	4470	4860	5280	5630	5810	6120	6510	6690
	Triple lbs.	2530	3070	3430	3840	4170	4530	4920	5250	5410	5700	6070	6230
18.4R46	Single lbs.	3300	3860	4400	4940	5360	5840	6150	6600	6950	7400	7850	8050
	Dual lbs.	2900	3400	3870	4350	4720	5140	5410	5810	6120	6510	6910	7080
	Triple lbs.	2710	3170	3610	4050	4400	4790	5040	5410	5700	6070	6440	6600
20.8R38	Single lbs.	3640	4300	4800	5360	5840	6400	6800	7150	7600	8050	8550	8800
	Dual lbs.	3200	3780	4220	4720	5140	5630	5980	6290	6690	7080	7520	7740
	Triple lbs.	2980	3530	3940	4400	4790	5250	5580	5860	6230	6600	7010	7220
20.8R42	Single lbs.	3740	4540	5080	5680	6150	6800	7150	7600	8050	8550	8800	9350
	Dual lbs.	3290	4000	4470	5000	5410	5980	6290	6690	7080	7520	7740	8230
	Triple lbs.	3070	3720	4170	4660	5040	5580	5860	6230	6600	7010	7220	7670
24.5R32	Single lbs.	4300	5080	5840	6400	7150	7600	8250	8800	9100	9650	10200	10500
	Dual lbs.	3780	4470	5140	5630	6290	6690	7260	7740	8010	8490	8980	9240
	Triple lbs.	3530	4170	4790	5250	5860	6230	6770	7220	7460	7910	8360	8610
30.5LR32	Single lbs.	5080	6150	6950	7600	8550	9100	9650	10500	11000	11700	12000	12800
	Dual lbs.	4470	5410	6120	6690	7520	8010	8490	9240	9680	10300	10560	11260
	Triple lbs.	4170	5040	5700	6230	7010	7460	7910	8610	9020	9590	9840	10500

LOAD/INFLATION CHART - METRIC SIZE RADIAL TIRES

Tire Size	Inflation Pressure	6 PSI	9 PSI	12 PSI	15 PSI	17 PSI	20 PSI	23 PSI	26 PSI	29 PSI	35 PSI	41 PSI	46 PSI
320/85R34	Single lbs.	1760	2150	2470	2830	3200	3520	3860	4080	4300	4540		
	Dual lbs.	1550	1890	2170	2490	2820	3100	3400	3590	3780	4000		
	Triple lbs.	1440	1760	2030	2320	2620	2890	3170	3350	3530	3720		
320/90R54	Single lbs.	2340	2830	3300	3740	4300	4680	5200	5520	5680	6000	6600	7150
	Dual lbs.	2060	2490	2900	3290	3780	4120	4580	4860	5000	5280	5810	6290
	Triple lbs.	1920	2320	2710	3070	3530	3840	4260	4530	4660	4920	5410	5860
380/90R50	Single lbs.	2910	3520	4080	4680	5200	5840	6400	6800	6950	7600		
	Dual lbs.	2560	3100	3590	4120	4580	5140	5630	5980	6120	6690		
	Triple lbs.	2390	2890	3350	3840	4260	4790	5250	5580	5700	6230		
380/90R54	Single lbs.	3000	3640	4300	4800	5520	6000	6600	6950	7400	7850	8550	9350
	Dual lbs.	2640	3200	3780	4220	4860	5280	5810	6120	6510	6910	7520	8230
	Triple lbs.	2460	2980	3530	3940	4530	4920	5410	5700	6070	6440	7010	7670
420/80R46	Single lbs.	2910	3520	4080	4680	5360	5840	6400	6800	7150	7600	8250	8800
	Dual lbs.	2560	3100	3590	4120	4720	5140	5630	5980	6290	6690	7260	7740
	Triple lbs.	2390	2890	3350	3840	4400	4790	5250	5580	5860	6230	6770	7220
420/90R30	Single lbs.	2680	3200	3740	4180	4800	5360	5840					
	Dual lbs.	2360	2820	3290	3680	4220	4720	5140					
	Triple lbs.	2200	2620	3070	3430	3940	4400	4790					
480/70R30	Single lbs.	2600	3080	3640	4180	4680	5200	5680	6000	6400	6800	7400	7850
	Dual lbs.	2290	2710	3200	3680	4120	4580	5000	5280	5630	5980	6510	6910
	Triple lbs.	2130	2530	2980	3430	3840	4260	4660	4920	5250	5580	6070	6440
480/70R34	Single lbs.	2760	3300	3860	4400	4940	5520	6150	6400	6600	7150	7850	8550
	Dual lbs.	2430	2900	3400	3870	4350	4860	5410	5630	5810	6390	6910	7520
	Triple lbs.	2260	2710	3170	3610	4050	4530	5040	5250	5410	5860	6440	7010
480/80R38	Single lbs.	3300	3960	4540	5200	5840	6600	7150	7600	7850	8550		
	Dual lbs.	2900	3480	4000	4580	5140	5810	6290	6690	6910	7520		
	Triple lbs.	2710	3250	3720	4260	4790	5410	5860	6230	6440	7010		
480/80R42	Single lbs.	3420	4080	4800	5520	6150	6950	7600	8050	8250	8800	9650	10500
	Dual lbs.	3010	3590	4220	4860	5410	6120	6690	7080	7260	7740	8490	9240
	Triple lbs.	2800	3350	3940	4530	5040	5700	6230	6600	6770	7220	7910	8610
480/80R46	Single lbs.	3640	4300	5080	5680	6400	7150	7850	8250	8550	9350		
	Dual lbs.	3200	3780	4470	5000	5630	6290	6910	7260	7520	8230		
	Triple lbs.	2980	3530	4170	4660	5250	5860	6440	6770	7010	7670		
480/80R50	Single lbs.	3740	4540	5200	6000	6800	7600	8250	8550	9100	9650	10500	11400
	Dual lbs.	3290	4000	4580	5280	5980	6690	7260	7520	8010	8490	9240	10030
	Triple lbs.	3070	3720	4260	4920	5580	6230	6770	7010	7460	7910	8610	9350
520/85R42	Single lbs.	4080	4940	5680	6600	7400	8250	9100					
	Dual lbs.	3590	4350	5000	5810	6510	7260	8010					
	Triple lbs.	3350	4050	4660	5410	6070	6770	7460					
520/85R46	Single lbs.	4300	5080	6000	6800	7600	8550	9350	9900	10200	11000	12000	12800
	Dual lbs.	3780	4470	5280	5980	6690	7520	8230	8710	8980	9680	10560	11260
	Triple lbs.	3530	4170	4920	5580	6230	7010	7670	8120	8360	9020	9840	10500
620/70R46	Single lbs.	4680	5680	6600	7600	8550	9350	10500	11000	11400	12000		
	Dual lbs.	4120	5000	5810	6690	7520	8230	9240	9680	10030	10560		
	Triple lbs.	3840	4660	5410	6230	7010	7670	8610	9020	9350	9840		

RIDE, TRACTION & PERFORMANCE

LOAD/INFLATION CHART - METRIC SIZE RADIAL TIRES (CONT.)

Tire Size	Inflation Pressure	6 PSI	9 PSI	12 PSI	15 PSI	17 PSI	20 PSI	23 PSI	26 PSI	29 PSI	35 PSI	41 PSI	46 PSI
620/70R42	Single lbs.	4540	5360	6400	7150	8050	9100	9900					
	Dual lbs.	4000	4720	5630	6290	7080	8010	8710					
	Triple lbs.	3720	4400	5250	5860	6600	7460	8120					
650/85R38	Single lbs.	5520	6600	7850	8800	9900	11000	12000	12800	13200	14300		
	Dual lbs.	4860	5810	6910	7740	8710	9680	10560	11260	11620	12580		
	Triple lbs.	4530	5410	6440	7220	8120	9020	9840	10500	10820	11730		
710/70R38	Single lbs.	5360	6400	7400	8550	9650	10700	11700	12300	12800	13600		
	Dual lbs.	4720	5630	6510	7520	8490	9420	10300	10820	11260	11970		
	Triple lbs.	4400	5250	6070	7010	7910	8770	9590	10090	10500	11150		
710/70R42	Single lbs.	5520	6600	7850	8800	9900	11000	12300	12800	13600	14300	15700	17100
	Dual lbs.	4860	5810	6910	7740	8710	9680	10820	11260	11970	12580	13820	15050
	Triple lbs.	4530	5410	6440	7220	8120	9020	10090	10500	11150	11730	12870	14020
800/70R38	Single lbs.	6400	7600	9100	10200	11700	12800	14300					
	Dual lbs.	5630	6690	8010	8980	10300	11260	12580					
	Triple lbs.	5250	6230	7460	8360	9590	10500	11730					
900/50R42	Single lbs.	5680	6800	7850	9100	10200	11400	12300					
	Dual lbs.	5000	5980	6910	8010	8980	10030	10820					
	Triple lbs.	4660	5580	6440	7460	8360	9350	10090					

Numbers shown are metric, multiply by 2.2 for U.S. conversion.

LOAD/INFLATION CHART - MFD TIRES

Tire Size Standard	Inflation Pressure	6 PSI	7 PSI	8 PSI	9 PSI	10 PSI	12 PSI	14 PSI	16 PSI	18 PSI	20 PSI	22 PSI	24 PSI
14.9R30	Single lbs.	NR	NR	2150	2270	2470	2680	3000	3200	3420	3640	3860	4080
	Dual lbs.	1600	1740	1890	2000	2170	2360	2820	2820	3010	3200	3400	3590
	Triple lbs.	1490	1620	1760	1860	2030	2200	2620	2620	2800	2980	3170	3350
Tire Size Metric	Inflation Pressure	6 PSI	7 PSI	9 PSI	10 PSI	12 PSI	13 PSI	15 PSI	17 PSI	20 PSI	23 PSI	26 PSI	29 PSI
380/85R30	Single lbs.	NR	NR	2600	2830	3000	3200	3420	3860	4300	4800		
	Dual lbs.	1890	2110	2290	2490	2640	2820	3010	3400	3780	4220		
	Triple lbs.	1760	1970	2130	2320	2460	2620	2800	3170	3530	3940		
380/85R34	Single lbs.	NR	NR	2760	3000	3200	3420	3640	4080	4540	5080	5360	5520
	Dual lbs.	2000	2240	2430	2640	2820	3010	3200	3590	4000	4470	4720	4860
	Triple lbs.	1860	2080	2260	2460	2620	2800	2980	3350	3720	4170	4400	4530
480/70R34	Single lbs.	NR	NR	3300	3640	3860	4180	4400	4940	5520	6000	6400	6600
	Dual lbs.	2430	2710	2900	3200	3400	3680	3870	4350	4860	5280	5630	5810
	Triple lbs.	2260	2530	2710	2980	3170	3430	3610	4050	4530	4920	5250	5410
380/80R38	Single lbs.	NR	NR	2760	3000	3200	3420	3640	4180	4540	5080	5360	5520
	Dual lbs.	2000	2240	2430	2640	2820	3010	3200	3680	4000	4470	4720	4860
	Triple lbs.	1860	2080	2260	2460	2620	2800	2980	3430	3720	4170	4400	4530

PREVENTING POWERHOP

ON MFD TRACTORS, POWERHOP OCCURS WHEN THE FRONT AXLE ATTEMPTS TO OUT-PULL THE REAR AXLE. ON 4WD TRACTORS, POWERHOP OCCURS WHEN THE REAR AXLE ATTEMPTS TO OUT-PULL THE FRONT AXLE.

Regardless of model or manufacturer, under certain conditions tractors may hop fore and aft or the tires may bounce up and down. You may experience this type of out-of-phase movement that results in a twisting motion of the tractor. Engineers call this type of movement "powerhopping" but some customers have termed it "grasshoppering." This results most commonly in heavy tillage operations with pull-type equipment.

What causes powerhopping?

- The tractor is not properly matched to the implement.
- Tire pressures are not properly balanced from front to rear.
- Improper tire size combinations are installed on the tractor (creating improper lead/lag ratio on the MFD equipped tractor).
- The operator is attempting to go too fast for the implement, the operation, or the operating conditions.
- Improper front to rear weight ratio on the tractor.

Possible solutions for powerhopping problems.

If powerhop occurs after following all of the guidelines on leveling implement tire size, weight split, ballast type, and inflation pressures, make the following adjustments to inflation pressures:

MFD

Raise front inflation pressure by 2 PSI. If powerhop is not eliminated, further front tire inflation pressure increases in 2 PSI increments is advised until hop is eliminated. Rear tire inflation pressures should remain at the correct pressures for the load. The maximum front pressure should not exceed 6 psi above the maximum rated pressure for the tire (radial or bias.) If tractor continues to powerhop, take weight off of the front axle.

4WD

Raise the rear inflation pressure from the correct inflation by 2 PSI. If powerhop is not eliminated, increasing rear tire inflation pressure in 2 PSI increments is advised until hop is eliminated. The maximum pressure should not exceed 6 PSI above the maximum rated pressure for the tire (radial or bias). If raising the rear pressure fails to control hop, take weight off of the rear of the tractor. On extremely steep hillside operations, keep the fronts at the correct pressure for the load and raise the rear pressures.

RIDE, TRACTION & PERFORMANCE

HYDRAULIC PRODUCTIVITY

The more demanding your application the greater the need to properly manage the tractor hydraulic system. Proper circuit connection, use of the flow control, and removal of unintended circuit restrictions can improve hydraulic system performance.

A basic hydraulic circuit consists of:

- A pump
- Control valve(s)
- Hydraulic function (steering, implement, 3-point hitch, or other)

Larger implements equipped with several lift cylinders will require more flow to properly lift and lower the implement. If the flow control is set to deliver the necessary flow requirement, the operator can activate the circuit and tend to other necessary activities while the hydraulic circuit completes its cycle.

AFTER CONNECTION, OPERATE THE CIRCUIT AND ADJUST THE FLOW CONTROL DIAL UNTIL THE DESIRED RAISE/LIFT TIME IS OBTAINED.

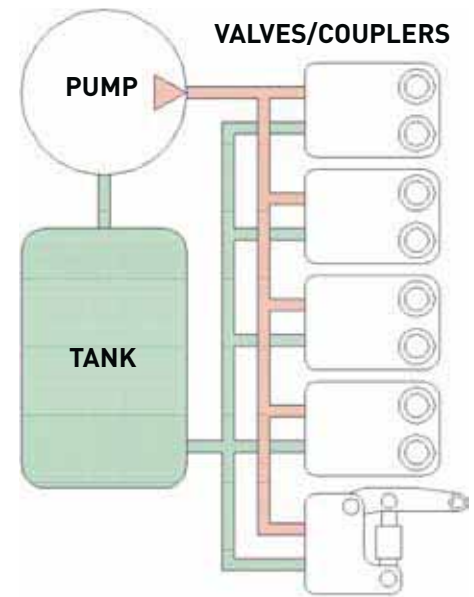

HYDRAULIC CONNECTION BASICS

HYDRAULIC CIRCUITS MUST BE PROPERLY CONNECTED TO THE TRACTOR TO OPERATE CORRECTLY.

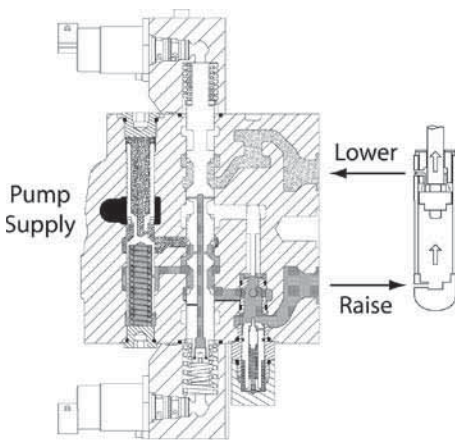

◀ Implement Raise/Lower Cylinders

Implement raise/lower cylinders should be connected with the remote valve load check in the raise side of the circuit. If the cylinder is not connected in this way, the implement will settle while the control valve is in the neutral position.

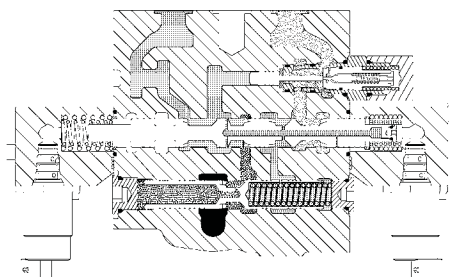

◀ Hydraulic Orbital Motors

- Orbital motors (sprayers, planters, etc.) should be connected with the motor supply connected to the lower side of the circuit.
- Orbital motor supply/return lines should not contain load checks or other in-line restrictions.
- The return side of the circuit should be connected to a motor return port. A motor return connection minimizes restrictions and improves operating efficiency in the hydraulic circuit.

INSTRUMENTATION

THE KEY TO EFFICIENT TRACTOR OPERATION IS KNOWING WHAT YOUR TRACTOR IS DOING AND UNDERSTANDING WHAT'S GOING ON INTERNALLY. THE MOST EFFECTIVE TOOL FOR ACCOMPLISHING THIS IS THE TRACTOR'S OWN INSTRUMENTATION.



◀ TRACTOR MONITOR (STANDARD)

The Tractor Monitor displays basic tractor operations and provides an interface for configuration and calibration.

- Engine Oil Pressure
- Engine Coolant Temperature
- Fuel Level
- Operation Indicators (gear, direction, etc.)
- Warning Indicators

◀ PERFORMANCE MONITOR (OPTIONAL)

The Performance Monitor (optional) displays performance related functions including:

- Engine Power (electronic engines only)
- Area Accumulation
- Timer Function
- Slip Percent
- Remote Hydraulic Flows
- Remote Hydraulic Timers
- Service Reminders
- Automatic Engine Shut-down Protection
- Electronic End of Row Function (2003 and newer)

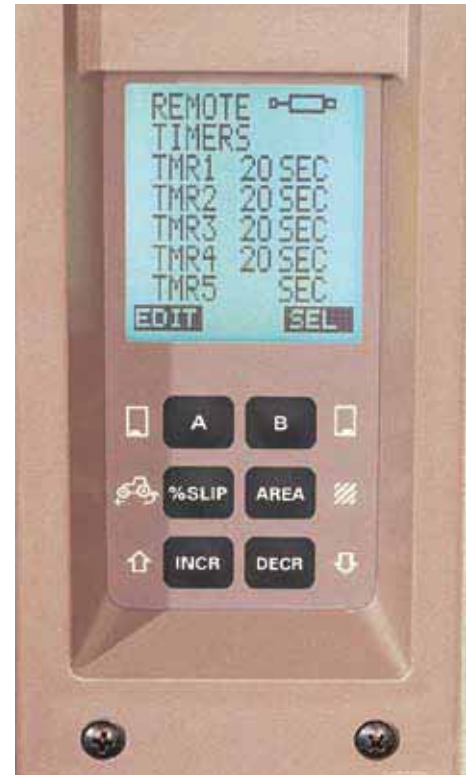

▲ If the tractor is equipped with a performance monitor, individual remote flow adjustment can be monitored on the screen.

TRACTOR CONTROLS - MAGNUM AND STEIGER TRACTORS



◀ The remote control levers on Magnum and Steiger tractors electronically activate the remote hydraulic circuits. The control levers have four positions:

- Raise
- Lower
- Neutral
- Float

Contact your Case IH dealer for a detailed demonstration on the proper use of the hydraulic controls.

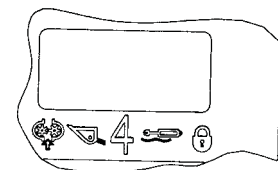

▲ Behind each control lever is a Remote Function control. The remote function control has five positions:

- Lock
- Loader
- No Float
- Hydraulic Motor
- Full Function

READY STOCK™

THE PARTS YOU NEED, RIGHT AT HAND.

The Ready Stock™ Parts Supply Locker program enables you to have parts stocked at your place of business.

WHY IS READY STOCK™ RIGHT FOR YOUR BUSINESS?

CONVENIENCE

- Parts are conveniently available when you need them, saving you both time and money
- Save yourself the trip – your dealer comes to you

COST SAVINGS

- No up-front cost – the locker and parts management are free (at participating dealerships¹)
- Pay only for the parts you use

INVENTORY MANAGEMENT

- Parts are stocked by your dealer and customized to your specific needs
- Eliminates obsolete inventory – parts are updated regularly

HOW DO I PARTICIPATE IN THE READY STOCK™ PARTS SUPPLY PROGRAM?

1. Contact your dealer to order a Ready Stock™ Parts Supply Locker
2. Your dealer will work with you on your customizable parts list
3. Your dealer will manage and restock inventory for you on an agreed upon schedule

¹ See your local Case IH dealer for details and qualification. Pricing and qualification for the Ready Stock™ Parts Supply Locker program are subject to your individual Case IH dealer.

² For commercial use only. This offer applies to purchases of genuine Case IH parts and related services made using the CNH Capital Commercial Revolving Account in part with the Ready Stock™ Parts Supply Locker program. Customer participation subject to credit qualification, available credit and good standing on all CNH Capital America LLC accounts. Program subject to change or cancellation without notice.

**FINANCING
IS AVAILABLE
THROUGH CNH CAPITAL²**

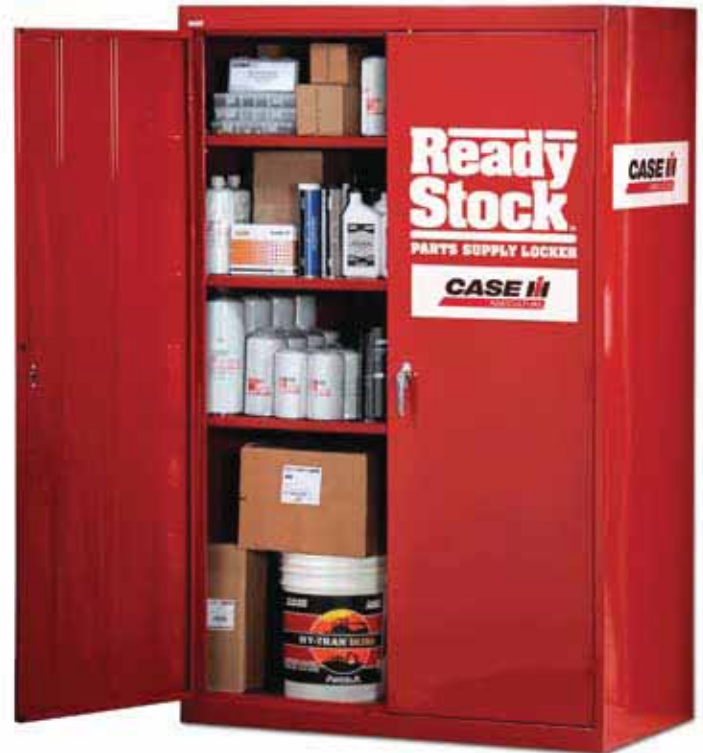

**Ready Stock™ Parts Supply Locker
46"W x 24"D x 72"H
#MC4350**

MAINTENANCE PARTS

ANTIFREEZE/COOLANT

Major diesel engine manufacturers estimate that more than 50% of engine failures are cooling-system related. Using a heavy-duty antifreeze/coolant designed for diesel use can help you avoid premature failure. Case IH heavy-duty coolants are formulated with additives to prevent corrosion and liner cavitation. Fully-formulated coolants are available in concentrate or in 50/50 mixture with reverse-osmosis treated, demineralized water.



1 Gal. Concentrate	B30201
1 Gal. 50/50 Pre-Mix	B30204
2.5-Gal. 50/50 Pre-Mix	B30205
55-Gal. Concentrate	B30302
55-Gal. 50/50 Pre-Mix	B30206

► **Fully-Formulated Antifreeze products that are user-friendly and reduce maintenance costs**

- Premixed and Concentrate
- All sizes from 1 gallon to 330 gallon tote

3-WAY TEST STRIPS

The 3 Way Test Kit is an easy and effective means of checking freeze point and liner pitting protection. Since liner pitting protection is a measure of nitrite and molybdate in engine coolant, this product is effective in measuring protection in all typical coolant chemistries. It is also effective in both ethylene and propylene glycol based coolants.

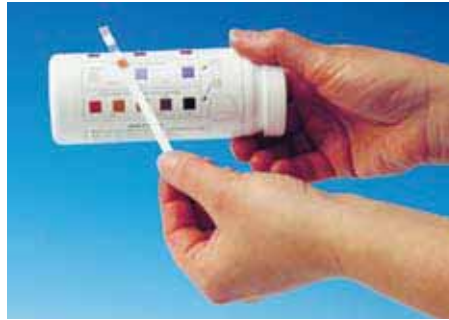

► **Multiple Supplemental Coolant Additive options**

- DCA4 and DCA2 chemistries
- Liquid or filter chemical additives
- Extended service coolants

► **Broad range of Coolant Analysis Services**

- On-site testing with 3-way test strip
- Monitor laboratory analysis program

CC2602	US	55 pack bottle
CC2602A	US	4 pack
CC2602B	US	1 pack
CC2602M	Metric	55 pack bottle
CC2602AM	Metric	4 pack

► **Complete line of Cleaners**

- Restore (alkaline)
- Restore Plus (acidic)



MAINTENANCE PARTS



▲ CASE IH NO. 1™ ENGINE OIL

Your engine takes a tremendous pounding day in and day out. But you can protect and preserve it with the best engine oil available —CASE IH NO. 1.

CASE IH NO. 1 is a premium high performance diesel engine oil designed to stand up to the toughest operating conditions. Less susceptible to thermal and chemical breakdown No. 1 provides excellent oil consumption control and maximum engine wear protection.

Compare before you buy. Use the engine oil specifically designed for your equipment and field conditions. Prolong your hard working engine's life — use CASE IH NO. 1 heavy-duty engine oil.

135H EP GEAR LUBE

This premium extreme-pressure gear lubricant provides superior foam and oxidation stability and reduces the risk of corrosion and deposits that can cause costly damage to your equipment. It's formulated to stand up to high-temperature conditions.

Uniquely prevents objectionable deposits and corrosion in gear cases, bearing rollers, races and thrust washers.



▲ CASE IH HY-TRAN ULTRA®

Up to 70% of all transmission and hydraulic system failures are fluid related. So protect and preserve your equipment with Hy-Tran Ultra and prevent costly downtime. It's the result of years of Case IH lubricant research.

Hy-Tran Ultra is blended to provide optimum machine performance and long life in the most severe operating conditions.

Provides superior wear protection for hydraulic components, drive train gears, and other transmission parts.

Controlled frictional characteristics provide safe, smooth operation of wet brakes and clutches.

Excellent filterability provides extra protection against system contamination.

▲ CASE IH ANTIFREEZE/ COOLANT

- Case IH coolants contain a chemical and additive package that helps prevent cavitation, erosion of liners, and corrosion of water pumps, yet is formulated to avoid radiator solder bloom and seal deterioration caused by many competitive coolants
- Pre-mixed products contain a high-quality, deionized water to prevent scaling
- Also available in 55-gallon drums or 330-gallon totes for competitive bulk pricing



▲ SYSTEMGARD®... THE EASY WAY TO AVOID COSTLY REPAIRS!

Why risk costly system breakdowns and downtime? Let SYSTEMGARD lubrication analysis tell you what's really going on inside your engine, transmission and hydraulic system.

Detect problems early, spot trends and keep small easily fixed problems from becoming serious ones.

SYSTEMGARD...the best "early warning system" on the market.

CUSTOMIZED MAINTENANCE INSPECTIONS

Everyone agrees that routine inspections by trained technicians are essential to good maintenance. Inspections not only need to be routine, they need to be consistent with the needs of the equipment and its owner.

Our Customized Maintenance Inspection programs are based upon prearranged inspections at intervals consistent with your needs. A professional and systematic approach to equipment service can:

- Reduce costly downtime
- Schedule repair maintenance
- Extend the service life of your equipment
- Increase machine productivity

Ask about CMI today!

MAINTENANCE PARTS

MAGNUM TRACTORS

MODELS

7110/7120

Qty.	Filter No.	Description
1	A77537*	Lube
1	J919562**	Lube
1	A77470 or	Fuel Kit
1	J930942	Fuel (primary)
1	J903640	Fuel (secondary)
1	1971728C1	Hydraulic
1	1346028C1+	Trans. (Aux.)
1	A171255	Air (Outer)
1	A171256	Air (Inner)
1	143481C92	Cab Air
1	87543798	Carbon Cab Filter
1	J100304	Water Filter Kit

* Prior to Engine S/N 45500128
 ** Engine S/N 45500128 & After
 + After Transmission S/N AJB0044915

MODELS

7130/7140/7150

Qty.	Filter No.	Description
1	A77537*	Lube
1	J919562**	Lube
1	A77470 or	Fuel Kit
1	J930942	Fuel (primary)
1	J903640	Fuel (secondary)
1	1971728C1	Hydraulic
1	1346028C1+	Trans. (Aux.)
1	A171255	Air (Outer)
1	A171256	Air (Inner)
1	143481C92	Cab Air
1	87543798	Carbon Cab Filter
1	J100304	Water Filter Kit

* Prior to Engine S/N 45500595
 ** Engine S/N 45500595 & After
 + After Transmission S/N AJB0044915

MODELS

7210/7220/7230/7240/7250

Qty.	Filter No.	Description
1	J919562	Lube
1	A77470 or	Fuel Kit
1	J930942	Fuel (primary)
1	J903640	Fuel (secondary)
1	D139225*	Fuel (in-line)
1	194199A1**	Fuel (in-line)
1	1971728C1	Hydraulic
1	1346028C1	Trans. (Aux.)
1	A171255	Air (Outer)
1	A171256	Air (Inner)
1	143481C92	Cab Air
1	87543798	Carbon Cab Filter
1	J100304	Water Filter Kit

* Prior to Engine S/N JJA0064978
 ** P.I.N. JJA0064978 & After

MODELS

8910/8920/8930/8940/8950

Qty.	Filter No.	Description
1	J919562	Lube
1	A77470 or	Fuel Kit
1	J930942	Fuel (primary)
1	J903640	Fuel (secondary)
1	194199A1	Fuel (in-line)
1	1971728C1	Hydraulic
1	1346028C1	Trans. (Aux.)
1	A171255	Air (Outer)
1	A171256	Air (Inner)
2	303748A1	Cab Air
1	240886A1	Cab Air (recirculating)
1	J100304	Water Filter Kit

MODELS

MX180/MX200/MX210/MX220/MX230

Qty.	Filter No.	Description
1	J919562	Lube
1	A77470 or	Fuel Kit
1	J930942	Fuel (primary)
1	J903640	Fuel (secondary)
1	194199A1	Fuel (in-line)
1	277311A1	Hydraulic
1	294721A1*	Hydraulic
1	402652A1**	Hydraulic
1	294292A1	Air (Outer)
1	294293A1	Air (Inner)
2	259288A1	Cab Air
1	87267363	Carbon Cab Filter
1	293615A1	Cab Air (recirculating)
1	J100304	Water Filter Kit

* P.I.N. JJA0105000 & After
 ** P.I.N. JAZ0125001 & After

MODELS

MX240/MX255/MX270/MX285

Qty.	Filter No.	Description
1	J919562	Lube
1	J329289	Fuel Kit
1	194199A1	Fuel (in-line)
1	277311A1	Hydraulic
1	294721A1*	Hydraulic
1	402652A1**	Hydraulic
1	294292A1	Air (Outer)
1	294293A1	Air (Inner)
2	259288A1	Cab Air
1	87267363	Carbon Cab Filter
1	293615A1	Cab Air (recirculating)
1	J100304	Water Filter Kit

* P.I.N. JJA0105000 & After
 ** P.I.N. JAZ0125001 & After

MODELS

Magnum 215/245/275/305

Qty.	Filter No.	Description
1	87356193	Filter, Fuel-CIH (25 Micron)
1	87360565	Filter, Fuel-CIH (3 Micron)
1	87349575	Filter, Lube Oil - CIH
1	87409371	Filter Primary Air - CIH
1	87409407	Filter Secondary Air - CIH
1	259288A1	Filter, Cab Fresh Air
1	87267363	Filter, Carbon Cab Filter
1	277311A1	Filter, Hydraulic
1	402652A1	Filter, Trans Control Circuit
1	293615A1	Filter, Cab Recirculation
1	87433010	Filter, Fuel Tank Vent
1	J100304	Element, Water Filter
1	87267363	Filter, Carbon Fresh Air (opt.)

MODELS

Magnum 335

Qty.	Filter No.	Description
1	87356193	Filter, Fuel-CIH (25 Micron)
1	87360565	Filter, Fuel-CIH (3 Micron)
1	87349575	Filter, Lube Oil - CIH
1	87409371	Filter Primary Air - CIH
1	87409407	Filter Secondary Air - CIH
1	259288A1	Filter, Cab Fresh Air
1	87267363	Filter, Carbon Cab Filter
1	277311A1	Filter, Hydraulic
1	402652A1	Filter, Trans Control Circuit
1	293615A1	Filter, Cab Recirculation
1	87433010	Filter, Fuel Tank Vent

MAINTENANCE PARTS

4WD TRACTORS

MODELS

9110/9130

Qty.	Filter No.	Description
1	A77537*	Lube
1	J919562**	Lube
1	A77470 or	Fuel Kit
1	J930942	Fuel (primary)
1	J903640	Fuel (secondary)
1	50-2689T91	Hydraulic Kit
1	1346028C1+ or	Hydraulic/Trans.
1	N9025+	Hydraulic/Trans.
1	196955A1	Hyd. (tank) - Suction
1	L102959+	Hyd. (tank) - Air Prec.
1	90-6443T1	Air (outer)
1	90-6444T1	Air (inner)
2	60-3846T2	Cab Air (recirculating)
1	J100304	Water Filter Kit

* Prior to Engine S/N 45500128
 ** Engine S/N 45500128 & After
 + After Transmission S/N JCB0003600

MODELS

9150 Prior to P.I.N. JCB0003600

Qty.	Filter No.	Description
1	28-36	Lube w/Cat 3306
1	1-2187	Lube w/Cummins
1	90-1158T1	Lube Bypass
1	6-1374	Fuel (primary) w/Cat 3306
1	28-25	Fuel (secondary) w/Cat 3306
1	28-25	Fuel w/Cummins f/Cougar
1	335341A1	Fuel w/Cummins
1	50-2689T91	Hydraulic Kit
1	196955A1	Hy. (tank) - Suction
1	1346028C1	Transmission
1	90-4233T1	Air (outer) - 11" Cleaner
1	90-4234S1	Air (inner) - 11" Cleaner
1	90-6017S1	Air (outer) - 14" Cleaner
1	90-6018T1	Air (inner) - 14" Cleaner
2	60-3846T2	Cab Air (recirculating)
1	J100304	Water Filter Kit
1	J318318	Water Coolant (precharged)

MODELS

9150 P.I.N. JCB0003600 & After

Qty.	Filter No.	Description
1	90-7101T1	Lube
1	335341A1	Fuel
1	1346028C1	Hydraulic/Trans.
1	N9025	Hydraulic/Trans.
1	196955A1	Hyd. (tank) - Suction
1	1346028C1	Transmission
1	90-6017S1	Air (outer)
1	90-6018T1	Air (inner)
2	60-3846T2	Cab Air (recirculating)
1	J100304	Water Filter Kit
1	J318318	Water Coolant (precharged)

MODELS

9170/9180 P.I.N. JCB0003600 & After

Qty.	Filter No.	Description
1	1-2335	Lube w/Cat 3406
1	1-2187	Lube w/Cummins
1	90-1158T1	Lube Bypass
1	1-2334	Fuel w/Cat 3406
1	28-35	Fuel w/Cummins
1	50-1911T91	Hydraulic Kit
1	196955A1	Hyd. (tank) - Suction
1	L102959	Hyd. (tank) - Air Prec.
1	1346028C1	Transmission
1	90-4203S1	Air (outer)
1	90-4204T1	Air (inner)
2	60-3846T2	Cab Air (recirculating)
1	60-4452T2*	Cab Air (inlet)
1	60-1981T1**	Cab Air (inlet)
1	J100304	Water Filter Kit
1	90-7707T1	Water Coolant (precharged)

* Prior to S/N 17900650
 ** S/N 17900650 & After

MODELS

9170/9180 P.I.N. JCB0003600 & After

Qty.	Filter No.	Description
1	90-7101T1	Lube
1	335341A1	Fuel
1	1346028C1 or	Hydraulic
1	N9025	Hydraulic
1	196955A1	Hyd. (tank) - Suction
1	90-4203S1	Air (outer)
1	90-4204T1	Air (inner)
1	60-3846T2	Cab Air (recirculating)
1	J100304	Water Filter Kit
1	90-7707T1	Water Coolant (precharged)

MODELS

9190

Qty.	Filter No.	Description
1	1-2187	Lube
1	90-1158T1	Lube Bypass
1	28-35	Fuel
1	18-498	Hydraulic
1	196955A1	Hyd. (tank) - Suction
1	1-3984T1	Transmission
1	1-3898S1	Air (outer)
1	1-3899	Air (inner)
1	54-304T1	Cab Air
1	J100304	Water Filter Kit

MAINTENANCE PARTS

4WD TRACTORS (CONT.)

MODELS 9210/9230/9240

Qty.	Filter No.	Description
1	J919562	Lube
1	A77470 or	Fuel Kit
1	J930942	Fuel (primary)
1	J903640	Fuel (secondary)
1	D139225	Fuel (in-line)
1	1346028C1 or	Hydraulic
1	N9025	Hydraulic
1	196955A1	Hyd. (tank) - Suction
1	90-6443T1	Air (outer)
1	90-6444T1	Air (inner)
1	60-4452T2	Cab Air (inlet), Ext.
2	60-3846T2*	Cab Air (recirculating)
2	60-3846T2**	Cab Air (recirculating)
1	60-6706T1**	Cab Air (recirculating)
1	60-6706T1+	Cab Air (recirculating)
1	60-3846T2+	Cab Air (recirculating)
1	J100304	Water Filter Kit
2	60-3846T2	Cab Air (recirculating)
1	J100304	Water Filter Kit

* Prior to P.I.N. JCB0028400
 ** P.I.N. JCB0028400 to JEE0031849
 + P.I.N. JEE031850 & After

MODELS 9250/9260

Qty.	Filter No.	Description
1	90-7101T1	Lube
1	335341A1	Fuel
1	1346028C1 or	Hydraulic
1	N9025	Hydraulic
1	196955A1	Hyd. (tank) - Suction
1	627975C3	Air (outer)
1	627976C1	Air (inner)
1	60-4452T2	Cab Air (inlet), Ext.
2	60-3846T2*	Cab Air (recirculating)
2	60-3846T2**	Cab Air (recirculating)
1	60-6706T1**	Cab Air (recirculating)
1	60-6706T1+	Cab Air (recirculating)
1	60-3846T2+	Cab Air (recirculating)
1	J100304	Water Filter Kit
1	J318318	Water Coolant (precharged)

* Prior to P.I.N. JCB0028400
 ** P.I.N. JCB0028400 to JEE0031849
 + P.I.N. JEE031850 & After

MODELS 9270/9280

Qty.	Filter No.	Description
1	90-7101T1	Lube
1	335341A1	Fuel
1	1346028C1 or	Hydraulic
1	N9025	Hydraulic
1	196955A1	Hyd. (tank) - Suction
1	90-4203S1++	Air (outer)
1	90-4204T1++	Air (inner)
1	132151A1***	Air (outer)
1	132149A1***	Air (inner)
1	60-4452T2	Cab Air (inlet), Ext.
2	60-3846T2*	Cab Air (recirculating)
2	60-3846T2**	Cab Air (recirculating)
1	60-6706T1**	Cab Air (recirculating)
1	60-6706T1+	Cab Air (recirculating)
1	60-3846T2+	Cab Air (recirculating)
1	J100304	Water Filter Kit
1	J318318	Water Coolant (precharged)

* Prior to P.I.N. JCB0028400
 ** P.I.N. JCB0028400 to JEE0031849
 *** P.I.N. JEE0033501 & After
 + P.I.N. JEE031850 & After
 ++ Prior to P.I.N. JEE0033501

MODELS 9310/9330

Qty.	Filter No.	Description
1	J919562	Lube
1	A77470 or	Fuel Kit
1	J930942	Fuel (primary)
1	J903640	Fuel (secondary)
1	D139225*	Fuel (in-line)
1	194199A1**	Fuel (in-line)
1	N9025	Hydraulic
1	196955A1	Hydraulic (tank)
1	90-6443T1*	Air (outer)
1	90-6444T1	Air (inner)
1	113988A1**	Air (outer)
1	113989A1	Air (inner)
1	60-4452T2	Cab Air
2	60-3846T2 (RH)	Cab Air (recirculating)
2	60-6706T1 (LH)	Cab Air (recirculating)
1	J100304	Water Filter Kit

* Prior to P.I.N. JEE0036501
 ** P.I.N. JEE0036501 & After

MODELS 9350

Qty.	Filter No.	Description
1	90-7101T1	Lube
1	335341A1	Fuel
1	N9025	Hydraulic/Trans.
1	132151A1	Air (outer)
1	132149A1	Air (inner)
1	60-4452T2	Cab Air
2	60-3846T2 (RH)	Cab Air (recirculating)
2	60-6706T1 (LH)	Cab Air (recirculating)
1	J100304	Water Filter Kit
1	J318318	Water Coolant (precharged)

MODELS 9370/9380/9390

Qty.	Filter No.	Description
1	90-7101T1	Lube
1	335341A1	Fuel
1	N9025	Hydraulic/Trans.
1	196955A1	Hydraulic (tank)
1	132151A1*	Air (outer)
1	132149A1*	Air (inner)
1	90-8300T1**	Air (outer)
1	90-8301T1**	Air (inner)
1	60-4452T2	Cab Air
1	60-3846T2 (RH)	Cab Air (recirculating)
1	60-6706T1 (LH)	Cab Air (recirculating)
1	J100304	Water Filter Kit
1	90-7707T1	Water Coolant (precharged) f/Models 9370 and 9380

* Prior to P.I.N. JEE006501
 ** P.I.N. JEE0036501 & After

MAINTENANCE PARTS

4WD TRACTORS (CONT.)

MODELS

Quadtrac

Qty.	Filter No.	Description
1	90-7101T1	Lube
1	335341A1	Fuel
1	N9025	Hyd./Trans. Axle Lube
1	254353A1*	Main Hyd.
1	196955A1	Hyd. (tank) - Suction
1	90-8300T1	Air (outer)
1	90-8301T1	Air (inner)
1	60-4452T2	Cab Air
1	60-3846T2 (RH)	Cab Air (recirculating)
1	60-6706T1 (LH)	Cab Air (recirculating)
1	J100304	Water Filter Kit

* P.I.N. JEE0069453 & After

MODELS

STX275/STX325

Qty.	Filter No.	Description
1	366700A1	Lube
1	J329289	Fuel
1	194199A1	(in-line)
2	1346028C1	Hydraulic
1	87404986	Hydraulic
1	87409371	Air (outer)
1	87409407	Air (inner)
1	259288A1	Cab Air
1	386751A1	Cab Air (recirculating)
1	J100304	Water Filter Kit
1	87267363	Filter, Carbon Fresh Air (opt.)

MODELS

STX375/STX425/STX440/STX450

Qty.	Filter No.	Description
1	324617A1	Lube
1	419858A1 or	Fuel (25 micron)
1	324619A1	Fuel (10 micron)
2	1346028C1	Hydraulic
1	87404986	Hydraulic
1	319468A1*	Air (outer)
1	319469A1*	Air (inner)
1	426020A1**	Air (outer)
1	426021A1**	Air (inner)
1	259288A1	Cab Air
1	386751A1	Cab Air (recirculating)
1	324618A1	Water Filter Kit
1	87267363	Filter, Carbon Fresh Air (opt.)

* Prior to P.I.N. JEE0099501

** P.I.N. JEE0099501 & After

MODELS

STX500

Qty.	Filter No.	Description
1	324617A1	Lube
1	419858A1 or	Fuel (25 micron)
1	324619A1	Fuel (10 micron)
2	1346028C1	Hydraulic
1	87404986	Hydraulic
1	87417040	Air (outer)
1	87417041	Air (inner)
1	259288A1	Cab Air
1	386751A1	Cab Air (recirculating)
1	324618A1	Water Filter Kit
1	87267363	Filter, Carbon Fresh Air (opt.)

MODELS

Steiger 280/330

Qty.	Filter No.	Description
1	87409371	Filter, Primary Air
1	87409407	Filter, Secondary Air
1	87349575	Filter, Engine Oil
1	J940632	Thermostat, Water Filter
1	S302030	Filter, Coolant
1	87360565	Filter, Fuel (5 Micron)
1	87356193	Filter, Fuel (25 Micron)
1	87409376	Filter, Transmission
1	87409368	Filter, Cab
1	414219A1	Filter, Hydraulic
1	47131182	Filter, Hydraulic Oil
1	259288A1	Filter, A/C
1	87267363	Filter, Carbon Fresh Air (opt.)

MODELS

Steiger 335

Qty.	Filter No.	Description
1	87409371	Filter, Primary Air
1	87409407	Filter, Secondary Air
1	87349575	Filter, Engine Oil
1	87579684	Thermostat, Water Filter
1	S302030	Filter, Coolant
1	87360565	Filter, Fuel (5 Micron)
1	87356193	Filter, Fuel (25 Micron)
1	87409376	Filter, Transmission
1	87409368	Filter, Cab
1	1346028C1	Filter, Element
1	47131182	Filter, Hydraulic Oil
1	259288A1	Filter, A/C
1	87267363	Filter, Carbon Fresh Air (opt.)

MAINTENANCE PARTS

4WD TRACTORS (CONT.)

MODELS

Steiger 380/430

Qty.	Filter No.	Description
1	87443711	Filter, Primary Air
1	87443714	Filter, Secondary Air
1	84818743	Filter, Engine Oil
1	84818745	Thermostat, Water Filter
1	87409376	Filter, Fuel
1	87409368	Filter, Transmission
1	414219A1	Filter, Cab
1	47131182	Filter, Hydraulic
1	259288A1	Filter, Hydraulic Oil
1	87267363	Filter, A/C
1	87267363	Filter, Carbon Fresh Air (opt.)

MODELS

Steiger 385/435/435Q/485/485Q

Qty.	Filter No.	Description
1	84818743	Filter, Engine Oil
1	84818745	Filter, Fuel
1	87409376	Filter, Transmission
1	87409368	Filter, Cab
1	1346028C1	Filter, Element
1	47131182	Filter, Hydraulic Oil
1	259288A1	Filter, A/C
1	87267363	Filter, Carbon Fresh Air (opt.)

MODELS

Steiger 480/480Q/530/530Q

Qty.	Filter No.	Description
1	87443711	Filter, Primary Air
1	87443714	Filter, Secondary Air
1	324617A1	Filter, Engine Oil
1	324618A1	Filter, Coolant
1	87366406	Filter, Fuel
1	87409376	Filter, Transmission
1	87409368	Filter, Cab
1	414219A1	Filter, Hydraulic
1	1957867C1	Filter, Screen
1	47131182	Filter, Hydraulic Oil
1	259288A1	Filter, A/C
1	87267363	Filter, Carbon Fresh Air (opt.)

MODELS

Steiger 535/535Q

Qty.	Filter No.	Description
1	87443711	Filter, Primary Air
1	87443714	Filter, Secondary Air
1	324617A1	Filter, Engine Oil
1	324618A1	Filter, Coolant
1	87366406	Filter, Fuel
1	87409376	Filter, Transmission
1	87409368	Filter, Cab
1	1346028C1	Filter, Element
1	1957867C1	Filter, Screen
1	47131182	Filter, Hydraulic Oil
1	259288A1	Filter, A/C
1	87267363	Filter, Carbon Fresh Air (opt.)





WWW.CASEIH.COM

SAFETY NEVER HURTS!™ Always read the Operator's Manual before operating any equipment. Inspect equipment before using it, and be sure it is operating properly. Follow the product safety signs, and use any safety features provided.

Case IH is a registered trademark of CNH America LLC. Any trademarks referred to herein, in association with goods and/or services of companies other than CNH America LLC, are the property of those respective companies.

CNH America LLC reserves the right to make improvements in design and changes in specifications at any time without notice and without incurring any obligation to install them on units previously sold. Specifications, descriptions and illustrative material herein are as accurate as known at time of publication, but are subject to change without notice. Availability of some models and equipment builds varies according to the country in which the equipment is used.

